



Gujarat Mineral Development Corporation Limited

Tender Document For

Supply of Soot Blower Mechanical spares for CFBC Boiler at

GMDC's 2x125 MW Akrimota Thermal Power Station

Tender Number: GMDC/POWER/ATPS/02/25-26

**Project Director
Akrimota Thermal Power Station (ATPS)
Gujarat Mineral Development Corporation Ltd.
(A Govt. Of Gujarat Enterprise)**

CIN: L14100GJ1963SGC001206, GST: 24AAACG7987P1ZT

**Village: Nanichher, Taluka: Lakhapat, District: Kutch, Gujarat-370602
E-mail: jndave@gmdcltd.co.in, Website: www.gmdcltd.com**



Contents

| Cl. No. | Particulars | Page No. |
|---------|---|----------|
| 1. | Purpose of the Document | 8 |
| 2. | About GMDC | 8 |
| 3. | Location of Work | 8 |
| 4. | About ATPS Project | 8 |
| 5. | General Instructions to Bidder | 9 |
| 5.1 | Cost of Bidding | 9 |
| 5.2 | Due Diligence | 9 |
| 4.3 | Clarification of Bidding Documents | 9 |
| 5.4 | Amendment of Tender Document | 9 |
| 5.5 | Contact Details | 10 |
| 5.6 | Language of Bid | 10 |
| 5.7 | Late Bids | 10 |
| 5.8 | Right to Accept Proposal | 10 |
| 5.9 | Site Visit | 11 |
| 5.10 | Period of Validity of Bids | 11 |
| 5.11 | Subcontract | 11 |
| 5.12 | Consortium / Joint Venture | 11 |
| 5.13 | Change in Law | 11 |
| 5.14 | Interpretation | 12 |
| 5.15 | Declaration | 12 |
| 6. | Earnest Money Deposit | 12 |
| 7. | Tender processing Fee | 13 |



| | | |
|-------------|---|-----------|
| 8. | Security Deposit | 13 |
| 9. | Procedure for Submission of the Bid | 14 |
| 10 | Eligibility and Qualification Criteria of Bidder | 15 |
| 10.1 | Experience | 15 |
| 10.2 | Financial | 16 |
| 10.3 | Site Visit Certificate | 16 |
| 10.4 | Blacklisting of the Bidder | 16 |
| 11 | Evaluation of Bids | 17 |
| 11.1 | Completeness of Bids | 17 |
| 11.2 | Tender Clarifications | 17 |
| 11.3 | Rejection of Bids | 17 |
| 11.4 | Opening of Bids | 17 |
| 11.5 | Selection of Bidder | 18 |
| 11.6 | Discussion | 18 |
| 11.7 | Acceptance of LOI | 18 |
| 12. | Scope of Work with BOQ | 19 |
| 13. | Period and Duration of Work | 22 |
| 14. | Liquidated Damages (LD) | 22 |
| 15 | Measurements | 23 |
| 16. | Transit Insurance | 24 |
| 17. | Goods & Service Tax | 24 |
| 18. | Payment | 24 |
| 19. | Mode of Payments | 25 |
| 20. | Performance Guarantee | 26 |
| 21. | Bankruptcy | 26 |



| | | |
|------------|--|-----------------|
| 22. | Notice | 26 |
| 23. | Canvassing Not Permitted | 27 |
| 24. | Non-Fulfillment of Terms and Condition of The Contract | 27 |
| 25. | General Conditions | 28 |
| 26. | Statutory Obligation | 29 |
| 27. | Termination of Contract | 31 |
| 28. | Governing Law | 31 |
| 29. | Jurisdiction | 31 |
| 30. | Arbitration | 31 |
| 31. | Completion of Work | 32 |
| 32. | Accident and Responsibilities of Bidder | 32 |
| 33. | Foreclosure | 33 |
| 34. | Force Majeure | 33 |
| | Annexure – A, Instruction to Bidders for Online Tendering | 35 |
| | Annexure – B List of Banks for submission on EMD | 36 |
| | Annexure – C Bank Detail for RTGS | 37 |
| | FORM – PA to PG | 38 to 44 |
| | PRICD BID FORM – PP | 45 |
| | Format of Bank Guarantee for EMD | 48 |
| | Format of Bank Guarantee for SD | 52 |
| | ANNEXURE-I (Drawings) | 56 to 74 |



TENDER NOTICE

Tender Number: GMDC/POWER/ATPS/02/25-26

| | |
|------------------------------------|--|
| Brief Description of work | Supply of Soot Blower Mechanical spares for CFBC Boiler at GMDC's 2x125 MW Akrimota Thermal Power Station |
| Location of Work | 2x125 MW Akrimota Thermal Power Station, Village: Nanichher, Taluka: Lakhpat, District: Kutch, Gujarat. |
| Period of contract | The period of contract will be 03 Months from the date of acceptance of LOI. |
| Estimated Contract Value | Approximately Rs 7.83 Lakh (Rupees Seven Lakh Eighty Three Thousand only) for total work excluding GST. |
| Availability of Tender | Tender Document will be available on the GMDC website (www.gmdcltd.com) and nprocure portal (https://gmdctender.nprocure.com). Price Bids shall be required to be submitted online only on the n-procure portal (https://gmdctender.nprocure.com). |
| EMD (Earnest Money Deposit) | Rs. 23,490.00/- (Rupees Twenty Three Thousand Four Hundred Ninety only) in Form of <ul style="list-style-type: none">➤ DD in favor of GMDC Ltd. Payable at Panandhro, Kutch➤ Bank Guarantee from Approved bank➤ Digital Mode, please note if payment is made through Digital Mode kindly submit the receipt of the same in the attached documents. RTGS details for payment (Annexure-B) <p>Bank of Baroda, Panandhro, Ta. Lakhapat, Kutch-370601, Account Number: 90580400000264 IFSC: BARB0DBPDRO</p> <p><i>Relaxation in terms of submission of EMD shall be given to the bidder who is holding valid Certificate issued under the MSME Act, 2006 on the date of submission of Tender.</i></p> |



| | |
|--|---|
| <p>Tender Processing Fee</p> | <p>Rs.1,500/- (One Thousand Five Hundred only) plus GST @ 18% aggregating to Rs.1,770 payable by Demand Draft/ Pay Order drawn in favor of “GMDC Ltd.” payable at Panandhro, kutch.</p> <p><i>Relaxation in terms of submission of Tender Processing Fee shall be given to the bidder who is holding valid Certificate issued under the MSME Act, 2006 on the date of submission of Tender.</i></p> |
| <p>Commencement of tender</p> | <p>From – 1st January 2026</p> |
| <p>Last date for download the tender document.</p> | <p>21st January 2026 up to 18.00 Hours</p> |
| <p>Last date of submission of bid through online</p> | <p>21st January 2026 up to 18.00 Hours</p> |
| <p>Last date of submission of physical documents i.e. EMD, Tender Processing Fee etc.</p> | <p>21st January 2026 up to 18.00 Hours at ATPS Office, GMDC, Nani chher.</p> |
| <p>Date and time for online opening of preliminary bid.</p> | <p>22 nd January 2026 at 18:10 Hours onwards</p> |
| <p>General and Important Terms and Conditions</p> | <ol style="list-style-type: none"> 1. GMDC reserves absolute right/discretion to accept and/or reject any or all the tenders received or invite fresh bid at any stage or split the work between more than one Bidders as the case may be. 2. The Bidders are required to quote the rate as per the terms and conditions mentioned in the Tender document. Conditional tender shall not be entertained and will be rejected summarily without assigning any reasons, whatsoever. 3. GMDC may issue amendments/corrigendum in the tender documents, schedule, forms etc. at any time during the period between publication of notice and submission of bids of the tender on website. The Bidders in their own interest are advised to visit the website regularly till the last date of submission of the bid. No separate newspaper advertisement will be released for amendments/corrigendum. 4. GMDC reserves the rights to modify or alter any Condition of the Tender. 5. The Bidders are advised to submit their price bid online on https://www.gmdctender.nprocure.com only. Physical price bid shall not be accepted and shall be rejected summarily without assigning any reasons, whatsoever. |



| | |
|--|--|
| | <p>6. Failure to submit online bid in stipulated time due to any reason whatsoever by any Bidder shall result in disqualification of bid. In such circumstances, bid submitted physically along with supporting documents, tender processing fees, EMD amount etc. shall not be considered as bid submitted and the same will be returned back to the Bidder without opening the same. GMDC reserves the right to take suitable decision in this regard.</p> |
|--|--|



1. Purpose of the Document

The Tender Document (this document) floated by GMDC (Gujarat Mineral Development Corporation Limited), A Government of Gujarat Enterprise is to select a successful bidder who would be responsible for carrying out the Supply of Soot Blower Mechanical spares for CFBC Boiler at Akrimota Thermal Power Station at the quoted commercials and executed contract terms & conditions.

2. About GMDC

Gujarat Mineral Development Corporation Limited herein after referred to as GMDC, a Government of Gujarat Enterprise, is a pioneer company in the field of mining for six decades, catering to the needs of the minerals and solid fuel for the industries based in Gujarat. GMDC's mining activities are spread all over Gujarat. It is currently dealing in minerals like Lignite, Bauxite, Fluorspar, Ball Clay, Silica sand and Manganese. GMDC has also set up a 250 MW lignite based Thermal Power Station at Nani Chher in Kutch, Wind power plants of 200.9 MW at Maliya, Jodiya, Godsar, Bhanvad, Bada, Varvada, Rojmal and Solar Power plant of 5 MW at Panandhro Project.

3. Location of Work

Akrimota Thermal Power Plant Station (ATPS) is located at Village Nani Chher of Lakhpat Taluka in Kutch District of the Gujarat State. The project is located about 150 kms from Bhuj. The nearest Railway Station and Airport is at Bhuj.

4. About ATPS

GMDC has 2*125 MW Thermal Power Project called ATPS. Both the units have been in commercial operation since May, 2006. It is getting Lignite from its own mines located at Mata no Madh and Umarsar. The water requirement for the power plant is taken from the nearest Kori Creek through a 1.4 KM long sea water intake channel. The CFBC boiler is used here as it is environment friendly and controls sulphur in the flue gas emission. A 100 metre thick green belt surrounds the entire site. State of the art technology DCS has been used.



5. General Instructions to Bidder

The section aims to provide guidelines/Instructions for Bidders, to be used while submitting the Proposals.

5.1 Cost of Bidding

The Bidder shall bear all costs associated with the preparation and submission of its bid and GMDC LTD., shall under no event or circumstance be held responsible or liable for these costs, regardless of the conduct or outcome of the bidding process.

5.2 Due Diligence

The Bidder is expected to and shall be deemed to have examined all instructions, forms, terms and specifications and other information in this Tender Document. The bid should be precise, complete and in the prescribed format as per the requirement of the Tender Document. Failure to furnish all information required by the Tender Document or submission of a bid not responsive to the Tender Document in every respect will be at the Bidder's risk and may result in rejection of the bid. GMDC LTD. shall at its sole discretion be entitled to determine the adequacy/ sufficiency of the information provided by the Bidder.

5.3 Clarification of Bidding Documents

GMDC LTD. shall make best efforts to respond to any request for clarification of the Tender Document. The response/clarification shall to the extent possible be made in writing.

5.4 Amendment of Tender Document

At any time before the deadline for submission of bids, GMDC LTD may modify the tender Document for any reason, whether at its own initiative or in response to a clarification requested by a prospective Bidder, modify the Tender Document by amending, modifying and/or supplementing the same. Any amendments/modifications in the tender document would be displayed on GMDC Web Site/nprocure website and all such amendments shall be binding on the Bidder without any further act or deed on GMDC LTD part. In the event of any amendment, GMDC LTD reserves the right to extend the deadline for the submission of



the bids, in order to allow prospective Bidder reasonable time in which to take the amendment into account while preparing their bids. GMDC LTD may at its sole discretion, extend this deadline for submission of bids by amending the bid documents.

5.5 Contact Details

All inquiries concerning this procurement are to be addressed to the following:

Project Director (ATPS)
Akrimota Thermal Power Station, Village: Nanichher, Taluka: Lakhapat, District: Kutch,
Gujarat-370602
E-mail: jndave@gmdcltd.co.in, Website: www.gmdcltd.com

5.6 Language of Bid

All Proposals and various documents related to these Proposals should be in English Language. All correspondence between GMDC LTD., and the Bidder would also be in English Language. Supporting Documents and Printed Literature furnished by the Bidder may be in another Language provided the same are accompanied by an accurate translation in English Language.

5.7 Late Bids

Any bid received by GMDC LTD. after the deadline for submission of bids prescribed by GMDC LTD., summarily rejected. GMDC LTD. shall not be responsible for any postal delay or non-receipt /non-delivery of the documents. No further correspondence on this subject will be entertained.

5.8 Right to Accept Proposal

GMDC LTD reserves the right to accept or reject any Proposal, and to annul the Proposal process and reject all Proposals at any time prior to award of contract, without thereby incurring any liability to the affected Bidder or any obligation to inform the affected Bidder of the grounds for such decision.



5.9 Site Visit

Bidders are advised to visit the site to study the actual working conditions, before submission of the bid and shall have to submit the site visit declaration in the prescribed format. The information/details given in the tender document are only to describe the magnitude of work and are for mere guidance to the Bidders.

Any neglect or failure on the part of the Bidder in obtaining necessary and reliable information upon the foregoing or any other matters affecting the contract shall not relieve him from any risks or liabilities or the entire responsibility from completion of the work at the contracted rates and time in strict accordance with the contract documents.

5.10 Period of Validity of Bids

Bids shall remain valid for 180 days after the date of bid opening prescribed by GMDC LTD, pursuant to the Tender schedule mentioned in this document. In exceptional circumstances, GMDC LTD. may solicit the Bidder's consent to an extension of the period of validity. The request and the response thereto shall be made in writing. Extension of validity period by the Bidder shall be unconditional.

5.11 Subcontract

The Successful bidder shall not assign or sub-contract any portion of this work without prior written consent of GMDC.

5.12 Consortium / Joint Venture

Consortium / Joint Venture are not allowed.

5.13 Change in Law

Nothing in this contract shall entitle the Bidder to claim additional payment against the work executed or being executed or likely to be executed upon the change in law by Government of India or State of Gujarat as regards any taxes, liabilities arising out of work contract, judgments of court etc. That nothing under the said laws shall create any additional liability on the GMDC over and above that set out herein. That unforeseen circumstances in the working of the said contract shall not entitle the Successful Bidder to



abandon or demand additional payment under a different head not originally mentioned herein and hence nothing except what is contained in the present contract shall constitute binding obligations between parties.

5.14 Interpretation

That no communication preceding or following the present tender shall have any bearing on the terms and conditions set out herein. That no contract, promise or obligation shall arise out of the said communication, over and above what is set out herein above. That the terms contained herein constitute the entire bargain between the parties and shall not be interpreted in the light of commercial correspondence between the parties.

5.15 Declaration

The Bidder should submit the declaration regarding unconditional acceptance of all the terms and conditions of the Tender document including Annexure and corrigenda if any and it has not enclosed any conditional offer as per FORM PD provided in the Tender Document.

GMDC is authorized to take suitable decision and action in case of requirement to amend/alter the contract conditions/quantities of the works/ extension of the contract period/allotment of additional works/revision of the rates of the work etc. if necessary, in the interest of GMDC.

The Successful bidder shall not change the constitution of the firm/name during the currency of the contract without prior approval of GMDC. Upon such change in constitution and/or name, Supplementary agreement to that effect shall be executed and if the SD is submitted in form of BG/FD then fresh BG in the name and/or constitution shall be submitted failing which necessary action as deemed fit by GMDC shall be taken.

6. Earnest Money Deposit

A non-interest-bearing Earnest Money Deposit 23,490.00/- (Rupees Twenty Three Thousand Four Hundred Ninety only) in any one of following form

- Demand Draft in favor of GMDC Limited Payable at ATPS.

OR



- Digital Mode, please note if payment is made through Digital Mode kindly submit the receipt of the same in the attached documents. RTGS details for payment (Annexure-B)
Bank of Baroda, Panandhro, Ta. Lakhapat, Kutch-370601,
Account Number: 90580400000264
IFSC: BARB0DBPDRO

Relaxation in terms of submission of EMD shall be given to the bidder who is holding valid Certificate issued under the MSME Act, 2006 on the date of submission of Tender.

7. Tender Processing Fee

The Tender Processing Fee is to be paid at the time of submission of supporting document of technical bid in the form of Demand Draft or Digital Mode NEFT Transaction of Rs. 1,500/- plus GST @ 18% (Rs. 270) aggregating Rs 1,770/- as mentioned in tender notice in the sealed technical bid cover.

If the amount mentioned in the DD or NEFT is found short, the tender will not be considered for scrutiny and will be out rightly rejected.

Relaxation in terms of submission of Tender Processing Fee shall be given to the bidder who is holding valid Certificate issued under the MSME Act, 2006 on the date of submission of Tender.

8. Security Deposit

8.1 Security Deposit is measure of liquidated damages sustained by GMDC for not performing the contract satisfactorily. Nothing herein above shall disentitle GMDC from claiming the damages actually sustained in the value over and above the Security Deposit.

8.2 The successful bidder shall submit security deposit of 10% of the total contract value excluding Goods & Service Tax (GST) within 10 days from the date of receipt of LOI in any one of following form.

- Demand Draft in favor of GMDC Limited Payable at ATPS.

OR

- Bank Guarantee issued by banks approved by Govt. Of Gujarat from time to time (except Co-Operative bank) in the form and manner acceptable to GMDC (Govt. GR is annexed at “B” for approved bank). It should be valid for a period of six months beyond the contract



period from the date of receipt of LOI and shall be renewed from time to time in case of requirement.

8.3 It shall be refunded to the Successful bidder, within a period of six months after satisfactory completion of the work and the due fulfillment of all the terms and conditions of the contract.

8.4 The Successful bidder shall obtain “No Dues Certificate”, and “Work Completion Certificate” from Project Director (PP & A) ATPS and shall submit the same to General Manager (Power) at HO, who after verification of the fact will arrange for refund of SD.

8.5 The successful bidder will also have to submit “NO DEMAND CERTIFICATE” along with the above mentioned certificate.

8.6 The SD deposited by the Successful bidder shall be forfeited if the successful bidder fails to adhere to fulfill the conditions of work order.

8.7 Security deposit shall not bear any interest under any circumstances.

8.8 GMDC will reserve the right to recover the charges or the liquidated damages from the Security Deposit in the following circumstances-

1. If the successful bidder or its employees causes any damage or destroy any property belonging to GMDC.
2. The shortfall amount of all compensations, penalties, and other sums of money payable by the successful bidder or recoveries to be made under the terms of this contract which is due but not paid by the successful bidder in full, etc.
3. Any other dues on account of statutory compliance.

9. Procedure for Submission of the Bid

9.1 Offers prepared in accordance with the procedures enumerated below.

9.2 Bid should be submitted **online** at www.nprocure.com on or before the last date and time as prescribed in this tender.

9.3 The Bidder should submit their bids in Three parts, these are

1. Prequalification bid (Details of EMD and Tender processing Fee),
2. Technical Bid
3. Price Bid.



9.4 Manual price bids or the bids submitted by e-mail etc. will not be accepted under any circumstances. No correspondence will be entertained on this matter.

9.5 Bidders are advised to follow the 'Instructions for Bids Submission' given annexure "A" for e-submission of the bids online through n-procure.

Documents should be submitted as per check list given in form "PA" through 'off-line' in the sealed cover super-scribed as **Technical Bid for Tender Number GMDC/POWER/ATPS/02/25-26 and Name of work: Supply of Soot Blower Mechanical spares for CFBC Boiler at GMDC's 2x125 MW Akrimota Thermal Power Station, Village: Nanichher, Taluka: Lakhpat, District: Kutch, Gujarat.**

Bids must be submitted as per the schedule (date & time) indicated in tender notice.

10. Eligibility and Qualification Criteria of Bidder

10.1 Experience

The Bidders should have following minimum experience of having successfully completed similar works during last 7 (seven) years ending on last day of November 2025 (i.e. period from 01.12.2018 to 30.11.2025):

A. Three similar completed works each having amount of Rs 2,58,390/- (Rupees Two Lakh Fifty Eight Thousand Three Hundred Ninety) or more during last 7 (seven) years. (i.e. period from 01.12.2018 to 30.11.2025)

OR

B. Two similar completed works each having amount of Rs 3,91,500.00/- (Rupees Three Lakh Ninety One Thousand Five Hundred Only) or more during last 7 (seven) years. (i.e. period from 01.12.2018 to 30.11.2025)

OR

C. One similar completed work having amount of Rs 6,26,400/- (Rupees Six Lakh Twenty Six Thousand Four Hundred) or more during last 7 (seven) years. (i.e. period from 01.12.2018 to 30.11.2025)



Similar works means the Bidders should have experience to carry out one or more following works for Government/Semi Government / Corporation/Private Limited Company and should have been carried out under the single LOI/Work Order/Agreement.

- Supply of industrial spares and should have been carried out under the single LOI/Work Order/Agreement

Bidder shall submit the details of work completed in form PC as provided in the Tender Document Separate year wise Statement of experience with work orders and work executed certificates (Work Completion Certificate) duly certified by the certificate issuing authority shall be submitted as supporting documents.

Copies of these supply orders should be attached with the Technical Bid

10.2 Financial

1. Bidder must have an average positive Net Worth as on last three financial year of 31.03.2023, 31.03.2024 and 31.03.2025.
2. Bidder must have a Minimum Average Turnover of Rs 3,13,200.00/- (Rupees Three Lakh Thirteen Thousand Two Hundred Only) for financial year ending on 31.03.2023, 31.03.2024 and 31.03.2025.
3. A certificate from Chartered Accountant regarding financial capacity shall be submitted as per format provided in FORM PC of the Tender Document.

10.3 Site Visit Certificate

The Bidders are requested to carry out site visit to understand the actual requirement of spares and specifications if any and should give a declaration of site visit as per the format provided in FORM PG of the Tender Document.

10.4 Blacklisting of the Bidder

The Bidder or its directors have not been blacklisted by any Government Organization. The Bidder will submit a declaration to this effect as per the format provided in FORM PD of the Tender Document. If at any time such declaration is found false, the bid will be rejected or if the contract work is already awarded, it will be terminated forthwith without payment of any compensation and the EMD/SD will be forfeited.



11. Evaluation of Bids

11.1 Completeness of Bids

GMDC, will examine the bids to determine whether they are complete, whether they meet all the conditions of the Tender Document and Technical Specifications, whether any computational errors have been made, whether required sureties have been furnished, whether the documents have been properly signed, and whether the Bid Documents are substantially responsive to the requirements of the Tender Document.

11.2 Tender Clarifications

The GMDC may at its discretion, seek from any or all bidders, clarifications on his/their bids, including technical information, documents and materials after technical bid opening but before opening of commercial bid.

11.3 Rejection of Bid

A bid that does not meet all eligibility criteria or is not responsive shall be rejected by GMDC. Submission of false or incorrect information, history of delayed work, reports of unprofessional conduct, among other things, shall be sufficient grounds for disqualification in technical bid.

11.4 Opening of Bids

Technical bids will be opened after verification of receipt of payment towards Tender Processing Fee and EMD. The eligible bidders will be able to view the technical bids after opening of technical bid. On verification of the supporting documents, technical qualification of the bidders will be assessed. The eligible bidders will be communicated the date and time of online opening of price bids by telephone or email. However, all bidders will be able to view the price bids online on their computers after opening of price bid.



11.5 Selection of Bidder

The contract will be awarded to the bidder who stands L1 in total price. The GMDC reserves its right to reject any or all tenders or split the job between more than one bidders without assigning any reason and thereby without incurring any liability to the affected successful bidder or Bidders or any obligation to inform the affected successful bidder or bidders of the grounds for GMDC Ltd., action/decision.

11.6 Discussion

It is essential for the successful bidders to quote the lowest price at the time of making the offer in their own interest. GMDC, however, will have the discretion to choose to enter any mode of discussion or not.

11.7 Acceptance of LOI and Issuance of Work Order:

1. GMDC, on acceptance of the offer, will issue Letter of Intent to the successful bidder, who will be required to confirm its acceptance of the LOI within 07 days from the date of receipt. If the successful bidder does not accept the LOI within stipulated period, the amount of the EMD paid will be forfeited and necessary further actions may be initiated as may be deemed fit by the GMDC.
2. The Successful bidder shall have to submit the Security Deposit within 10 days from the date of issuance of LOI. The Successful bidder shall submit the Security Deposit in the manner prescribed in this Tender Document. In case of failure to submit the security deposit, the amount of EMD will be forfeited and necessary further actions may be initiated as may be deemed fit by the GMDC.
3. GMDC will award the Work Order to the successful bidder, after the payment of Security Deposit, in token of acceptance of the terms and conditions of the contract, within 30 days from date of LOI. In case of any necessity arising after executing work order and during the execution of the work, which requires alteration/modifications in the agreement, the same can be made in writing after mutual understanding and consent of both the parties.



12. Scope of Work with BOQ

Supply of Soot Blower mechanical spares for CFBC Boiler at GMDC's 2x125 MW Akrimota Thermal Power Station as per following details specifications and Qty.

| Sr.No. | Area | Item Description | UOM | Qty. |
|--------|-------------|--|------|------|
| 1 | SOOT BLOWER | GRUB SREW,M10X30MM,HT,APPLICATION-SOOT BLOWER | NOS. | 20 |
| 2 | SOOT BLOWER | OIL SEAL 38 X 58 X 10MM | NOS | 20 |
| 3 | SOOT BLOWER | BEARING 6002/C2 | NOS | 20 |
| 4 | SOOT BLOWER | WOOL RUF KEY,PART NO.350549015,MODEL NO.IK-300, MAKE:ALSTOM,FOR GEAR COTE OTSEMBLY OF SOOT BLOWER | NOS | 8 |
| 5 | SOOT BLOWER | WOOD RUF KEY,PART NO.606,MODEL NO.IK-300, MAKE:ALSTOM,FOR GEAR COTE OTSEMBLY OF SOOT BLOWER | NOS | 8 |
| 6 | SOOT BLOWER | GASKET,PART NO.350501347, DRG NO.30656-0,MOC:MONEL SS,MODEL NO.IK-300,MAKE:ALSTOM,FOR SOOT BLOWER | NOS | 10 |
| 7 | SOOT BLOWER | GUIDE VALVE STEM,PART NO.350502510,DRG NO.302031-0110(SB-80),MODEL NO.IK-300, MAKE:ALSTOM,FOR POPPET VALVE ASSEMBLY OF SOOT BLOWER | NOS | 6 |
| 8 | SOOT BLOWER | PACKING WASHER, PART NO.35050284, MAKE : ALSTOM, FOR SOOT BLOWER | NOS | 6 |
| 9 | SOOT BLOWER | VALVE SPRING,PART NO.350502543,DRG NO.302051-0115,MODEL NO.IK-300, MAKE:ALSTOM,FOR POPPET VALVE ASSEMBLY OF SOOT BLOWER | NOS | 6 |
| 10 | SOOT BLOWER | STEM AND DISC ASSEMBLY,PART NO.350503284,DRG NO.309964-1023(178),MODEL NO.IK-300, MAKE:ALSTOM,FOR POPPET VALVE ASSEMBLY OF SOOT BLOWER | NOS | 8 |
| 11 | SOOT BLOWER | TRIGGER PIN,PART NO.350500038,DRG NO.301158-0119,MODEL NO.IK-300, MAKE:ALSTOM,FOR POPPET VALVE ASSEMBLY OF SOOT BLOWER | NOS | 10 |
| 12 | SOOT BLOWER | COTTER PIN,PART NO.3505010063,MODEL NO.IK-300, MAKE:ALSTOM,FOR POPPET VALVE ASSEMBLY OF SOOT BLOWER | NOS | 10 |



| | | | | |
|----|-------------|--|-----|----|
| 13 | SOOT BLOWER | VALVE STEM PACKING,PART NO.350502521,DRG NO.302034-0117(SB-82),MODEL NO.IK-300, MAKE:ALSTOM,FOR POPPET VALVE ASSEMBLY OF SOOT BLOWER | NOS | 10 |
| 14 | SOOT BLOWER | VALVE SPRING RETAINER,PART NO.350502851,DRG NO.301808-0113,MODEL NO.IK-300, MAKE:ALSTOM,FOR POPPET VALVE ASSEMBLY OF SOOT BLOWER | NOS | 10 |
| 15 | SOOT BLOWER | VALVE YOKE,PART NO.350502667,DRG NO.301142-0118(SB-70),MODEL NO.IK-300, MAKE:ALSTOM,FOR POPPET VALVE ASSEMBLY OF SOOT BLOWER | NOS | 10 |
| 16 | SOOT BLOWER | YOKE PIN,PART NO.350500060,MODEL NO.IK-300, MAKE:ALSTOM,FOR POPPET VALVE ASSEMBLY OF SOOT BLOWER | NOS | 10 |
| 17 | SOOT BLOWER | SEAT FLEXIBLE,PART NO.350504184,DRG NO.310666-2129(SB-835),MODEL NO.IK-300, MAKE:ALSTOM,FOR POPPET VALVE ASSEMBLY OF SOOT BLOWER | NOS | 10 |
| 18 | SOOT BLOWER | TRIP STUD,PART NO.350500351,MODEL NO.IK-300,DRG NO.305674-0115G(SB135) MAKE:ALSTOM,FOR POPPET VALVE ASSEMBLY OF SOOT BLOWER | NOS | 10 |
| 19 | SOOT BLOWER | CAM ASSEMBLY,PART NO.3505000351,MODEL NO.IK-300, MAKE:ALSTOM,FOR POPPET VALVE ASSEMBLY OF SOOT BLOWER | NOS | 6 |
| 20 | SOOT BLOWER | COTTER PIN ,PART NO.8636071934,MODEL NO.G9B, MAKE:ALSTOM,FOR ROTARY GOOSE NECK ASSEMBLYOF SOOT BLOWER | NOS | 6 |
| 21 | SOOT BLOWER | VALVE STEM PACKING,PART NO.3020340117,MODEL NO.IK-300,MAKE:ALSTOM,FOR SOOT BLOWER | NOS | 5 |
| 22 | SOOT BLOWER | VALVE YOKE,MAKE:ALSTOM,FOR SOOT BLOWER | NOS | 5 |
| 23 | SOOT BLOWER | VALVE YOKE PIN,PART NO.3091870117,MAKE:ALSTOM,FOR SOOT BLOWER | NOS | 5 |
| 24 | SOOT BLOWER | THRUST BALL BEARING,DRG NO.301213-1011J(824),MODEL NO.IK-300,MAKE:ALSTOM,FOR SOOT BLOWER | NOS | 4 |
| 25 | SOOT BLOWER | DEEP GROOVE NON FILLING SLOT BALL BEARING,PART NO.3E0540145,MAKE:ALSTOM,FOR SOOT BLOWER | NOS | 4 |



| | | | | |
|----|-------------|--|-----|----|
| 26 | SOOT BLOWER | INNER AND OUTER BEARING,PART NO.3505010056,MAKE:ALSTOM,FOR SOOT BLOWER | NOS | 10 |
| 27 | SOOT BLOWER | OIL SEAL,DRG NO.904532-0001,MAKE:ALSTOM,FOR SOOT BLOWER | NOS | 6 |
| 28 | SOOT BLOWER | NEEDLE ROLLER BEARING,PART NO.416592077,MODEL NO.IK-300,MAKE:ALSTOM,FOR SOOT BLOWER | NOS | 10 |
| 29 | SOOT BLOWER | TRIGGER ASSEMBLY,PART NO.3505010067,MODEL NO.G9B, MAKE:ALSTOM,FOR ROTARY SOOT BLOWER | NOS | 6 |
| 30 | SOOT BLOWER | SWIVEL TUBE,PATR NO.3E0 540065,MODEL NO.G9B, MAKE:ALSTOM,FOR SOOT BLOWER | NOS | 6 |
| 31 | SOOT BLOWER | VALVE YOKE PIN,PART NO.309187,MODEL NO.IK-300,MAKE-ALSTOM,APPLICATION-SOOT BLOWER | NOS | 4 |
| 32 | SOOT BLOWER | OPERATING LEVER FOR POPPET VALVE , MODEL -IK300, APPLICATION-SOOT BLOWER | NOS | 4 |

- All types of mechanical spares as per required quantity will be in scope of successful bidder.
- Prospective the bidder may visit at site for inspection of item to be quoted. For quote purpose the bidder has to take dimensions for fitment guarantee & collect sample of material for ascertaining MOC
- Successful Bidder's scope for Supply of all mechanical spares at GMDC's 2x125 MW Akrimota Thermal Power Station.
- The successful bidder shall have to supply the items in the BOQ as per the specifications otherwise shall be rejected.
- The successful bidder shall submit all kind of test certificate for chemical composition and mechanical properties of the supplied materials.
- GMDC has right to conduct any test of all spares, if required from Govt. Approved laboratory and results of same shall be binding to the successful bidder. The successful bidder may witness the same.
- Quantity of supply items may increase or decrease as per requirement of ATPS. GMDC reserves the right to remove any line item from the BOQ or decrease the quantity of supply and services of any items in the BOQ, as required (to be read along with Clause 24.3 of the



tender). In case quantity to be supplied is increased, variation should not be more than 20% of total contract value (including charges for supply), which shall be executed by the successful bidder at additional cost to GMDC, as per same terms & conditions of the original contract.

13. Period and Duration of Work

- 13.1** Supply of Soot Blower Mechanical spares for CFBC Boiler shall be carried out Within 03 months from the date of acceptance of LOI.
- 13.2** In case of any reason including adverse working conditions during execution of the contract that may compel suspension/closure of the contract, GMDC shall be at liberty to conclude/postpone/complete/terminate/foreclose this contract. No compensation or payment shall be made on account of afore-stated events. Decision of GMDC in this regard shall be final and binding to the successful bidder.
- 13.3** GMDC reserves the right to review and assess the performance of the work at any time during the contract period. In case of poor or unsatisfactory performance and/or breach of any terms and conditions of the contract, GMDC shall have discretion to take appropriate action including termination of the contract.

14. Liquidated Damages (LD) and Penalties

- 14.1** If the successful bidder fails to supply of the spares/materials as per the BOQ, GMDC shall reserve right to procure of the spares/material at the successful bidder's risk & cost with 20% administrative charges. GMDC shall reserve the right to determine the cost of supply of such spares/material.

(Bidder to note that penalty charges in clause 14.1 above is over and above the maximum cap on Liquidated Damages)
- 14.2** LD for late Supply of spares/materials will be levied at @ 0.1% of amount of supply of particular spares/material per day for any delay beyond the time specified in the tender documents with the maximum cap of 10 % of the total contract value.



- 14.3** Overall cap on late supply or installation of material the total LD shall be 10 % of the total contract value.
- 14.4** Looking to this, if the delay in completion of the supply happens which can be attributed to the successful bidder, the GMDC will be free to forfeit the EMD and /or SD, or both the EMD and SD.
- 14.5** For calculation of LD, date of acceptance of LOI shall be the reference date.

15. Measurements

- 15.1** Supply of spares Materials as per scope of supply shall be counted for payment, If the supply is not completed as per scope of supply and any part supply is done, then the part supply shall be counted for payment.
- 15.2** Material test certificate of all supplied spare along with material shall be submitted to GMDC by the Successful bidder.
- 15.3** The Successful bidder has to submit the material account statement along with the supply invoice measurement sheet. Any Invoice without material account statement shall not be processed, this may please be noted.
- 15.4** All the supplied credited materials shall be the property of GMDC.
- 15.5** All the materials to be supplied as per the scope of supply shall be credited to GMDC only.
- 15.6** The successful bidder shall ensure supply of all types of Materials timely to avoid any delay in completion of the work.



16. Transit Insurance:

- 16.1** Insurance –The Successful bidder shall take full responsibility to take all precautions to prevent loss or damage to the supplied material, works or part thereof for any reasons whatsoever (except for reasons which are beyond control of the Successful bidder or act of God, e.g. flood, riots, war, earthquake, etc.) and shall at his own cost, repair and make good the loss/damage to the supplied material so that on completion, the supplied material, works shall be in good order and condition and in conformity with the requirements of the Contract and instructions of the Project Authority, if any.
- 16.2** The cost of premiums shall be borne by the Successful bidder, and it shall be deemed to have been included in the tendered rate.

17. Goods & Service Tax

- 17.1** All bidders are required to submit their GST number and date in the bid. Bid received from unregistered bidder will not be considered and out rightly rejected.
- 17.2** Bidders are requested to quote their rates without GST. GST will be paid/adjusted/reimbursed to the Successful bidder as per prevailing rates and rules to the extent directly related to the Goods supplied by the Successful bidder under the said contract subject to production of documentary proof and the Successful bidder will mention the GST amount separately in the invoice/bill along with SAC/HSN Code under GST.

18. Payment

- 18.1** Successful bidder shall submit bill of all supplied items within 7 days after completion of work. Running Account Bill shall be processed after issuance of work order only.
- 1.** For payment of supply of items, Successful Bidder shall submit bills for
 - (i) 100% of supply charges for items, after material delivery and inspection at site, against Material Receipt Certificate and other necessary documents as required.
 - 2.** For payment of Supply of items, Successful Bidder shall submit bills for
 - (i) 100% of Supply charges of items, after completion of all supply as per the scope and certification of RA Bills from site.



18.2 Bill shall be submitted to the office of the Project Director (ATPS), ATPS with following documents:

- Details of spares / Material supplied with GMDC ATPS Gate Security certification, GMDC store certification & GMDC EIC and PMPL inspection certificate, test certificate of spares/equipments.
- Any other documents if any as prescribed by GMDC as and when requires.

18.3 The Running Account bills, submitted at the office of Project Director (ATPS) will be processed there considering following deductions

1. Income tax as per provision of Income Tax Act, and other Taxes (and surcharges) applicable in force from time to time
2. Cost of any other services provided / material supplied plus 20% administrative charge, if any, by the GMDC.
3. Liquidated damages,
4. Other deductions, if any.

18.4 100% of the payable amount arrived after considering above deduction (as mentioned in Clause 18.3 of the tender), will be paid by office of the Project Director (ATPS), within 30 days of submission of the invoice along with its detail and relevant documents.

18.5 GMDC shall be entitled to withhold payment if any of the invoices do not include the supporting documents required by the Owner (if any) and shall only be released after getting proper supporting documents, including statutory payments, from the Successful Bidder. No interest shall be paid by the Owner on any delayed/ disputed payment.

18.6 Payment shall be as per actual basis.

19. Mode Of Payment

The mode of payment will be by RTGS.



20. Performance Guarantee

- 20.1** For all supplied material, the successful bidder shall abide to accept the clause for the satisfactory performance of the supplied materials with guarantee of 12 months from date of commissioning or 18 months from the date of supply whichever is earlier.
- 20.2** During the guarantee period, If any problem surfaces, the Successful bidder shall carry out of repairing / replacing the material free of cost. All types of expenses for repair, replacement, labour, insurance, statutory etc shall be in Successful bidder's scope.
- 20.3** The guarantee covers all types of causes of non-satisfactory performances except natural calamities.

21. Bankruptcy

If the Successful bidder commits an act of Bankruptcy or goes into liquidation except for construction purposes, or if its business is carried on by a receiver, such receiver, liquidator or any person in whom the contract may become vested shall forthwith give notice thereof in writing to GMDC and in reasonable time during which he shall take all reasonable steps to prevent stoppage of performance of the contract, have the option of carrying out the contract subject to his or their providing such guarantees as may be required by GMDC but not exceeding the value of the work for the time being remaining unexecuted.

In the event of stoppage of performance under the contract, the period of option under this clause shall be decided by GMDC considering the situation, provided that the above option is not exercised, GMDC may terminate the contract by serving notice in writing to the Successful bidder. The power and provision so reserved to GMDC on taking of the work out of the Successful bidder's hands shall apply as far as they may be when the contract is so terminated.

22. Notice

Written notice shall be deemed to have been duly served if delivered to the individual or to the Successful bidder or to the Signing Authority of the GMDC from whom it is intended, or if delivered at or sent by mail or post, to the last business address known to him who gives the notice.



23. Canvassing Not Permitted

- 23.1** Bidder should not canvass their offer personally or otherwise by approaching the Chairman or the Member of GMDC. If any Bidder wants to make any representation regarding his offer, he should write to the Project Director (ATPS) if he desires, but personal and oral representations are not permitted.
- 23.2** In spite of the above clear instructions, any Bidder is found to canvass his offer or against his competitor's offer through personal approach to the competent authority or the officials of GMDC, their offer will be rejected without assigning any reason and the firm even is blacklisted.

24. Non-Fulfillment of Terms and Condition of The Contract

- 24.1** If the Successful bidder fails to carry out the work as per terms and conditions of the contract to the satisfaction of the GMDC, GMDC shall be entitled to forfeit the security deposit paid by the successful bidder. This however, shall not absolve the Successful bidder from his obligation to fulfill the contract. In such event, the GMDC shall have a right to complete and / or to get the work completed at the cost & risk of the Successful bidder and the Successful bidder shall be responsible to pay such cost incurred by the GMDC to complete the work and / or to get the work completed.
- 24.2** Likewise, if the Successful bidder does not fulfill the terms and conditions of the contract and does not carry out the work up to the entire satisfaction of GMDC, GMDC has the right to forthwith terminate the contract at its sole discretion, without assigning any reason, Under such events, the GMDC shall be entitled to forfeit the security deposit paid by the Successful bidder and the GMDC shall have a right to complete the work and / or to get the work completed at the risk and cost of the Successful bidder.
- 24.3** For any reasons, if it is required, the GMDC reserves rights to cancel, terminate, amend and / or alter the contract and / or bifurcate and / or reduce the contract work at any time without giving any notice or reason to the Successful bidder and without incurring any responsibility.



25. General Conditions

- 25.1** All the persons of the Successful bidder engaged must wear Helmet and Shoes and other PPEs. As and when required other personal protective wears shall also be provided to them by the successful bidder.
- 25.2** The Successful bidder shall take adequate statutorily prescribed insurance cover for all men and machinery engaged by him/it for performance of the work at site. Any statutory, legal, financial and other liabilities or insurance claims brought against the GMDC by an individual or by customers or by any such other persons who suffered damage due to negligence of the Successful bidder or his employees, the same shall be settled by the successful bidder at his cost.
- 25.3** The Successful bidder has to ensure supervision of the work through duly qualified and competent persons and also has to make sure that a responsible Manager/ Engineer full time available on work site to whom GMDC can issue the instruction and who can fulfill such instructions. Successful bidder shall appoint qualified Manpower.
- 25.4** The Successful bidder shall not change the constitution of the firm/name during the currency of the contract without prior approval of GMDC. Upon such change in constitution and/or name, Supplementary agreement to that effect shall be executed and if the SD is submitted in form of BG/FD than fresh BG in the name and/or constitution shall be submitted failing which necessary action as deemed fit by GMDC shall be taken.
- 25.5** All the staff members of the successful bidder shall carry Photo Identity Card while on duty.
- 25.6** The successful bidder shall provide necessary arrangement for transportation of manpower.
- 25.7** The successful bidder shall abide by the provision of the Motor Vehicle Act for machinery. Any consequences arising out of non-compliance of said Provisions will be at the successful bidder's sole risk and cost, for which GMDC will not be responsible for any compensation.
- 25.8** To meet the exigencies arising out of natural calamities or disaster or during any emergency, GMDC reserves the right to take away any of the equipment's / machineries deployed at the site with a mutually consented rate. A separate agreement will be made to this effect.



25.9 Project Director (ATPS) is authorized to take suitable decision and action in case of requirement to amend / alter the work order conditions /quantities of the works / extension of the work completion period / allotment of additional works / revision of the rates of the work etc. if necessary, in the interest of GMDC.

26. Statutory Obligations

- 26.1** That the successful bidder shall obtain license under the Factories Act and it shall pay wages and benefits in accordance with the applicable laws and shall not pay less than as notified by the Government Authorities from time to time and shall maintain the employment records as required under applicable laws.
- 26.2** That the successful bidder shall get his own License under Contract Labour (Regulation and Abolition) Act. It shall be binding to get the same renewed from time to time and shall maintain all the records as per the act.
- 26.3** That the successful bidder shall be responsible to enroll his employees, deduct, add and deposit in the relevant accounts the contributions as required under the Employees State Insurance Act, 1952 and the Employees Provident Funds and Miscellaneous Provisions Act 1952 and any other enactment's covered under the various applicable labour laws as well as maintain all books of records for the staff and employees deputed by it for this contract such as required under any laws applicable. The successful bidder shall also furnish a copy of such statements as documentary proof to the GMDC.
- 26.4** That if the successful bidder is not covered under the Employees State Insurance Act, 1952 then it shall be the duty of the successful bidder to take appropriate insurance cover under the Workmen Compensation Act and take Group Personal Accident Policy for all the employees deputed at the project site.
- 26.5** The successful bidder must issue to the employee's Identity card with their photos and shall also maintain relevant register.
- 26.6** That the successful bidder shall give leave/holiday to its workforce as per the provisions of labour laws applicable.



- 26.7** Every person deployed by the successful bidder in the plant must wear safety gadgets to be provided by the successful bidder.
- 26.8** Any statutory clearance, permission required for the work, its completion, Supply shall be in the successful bidder's scope.
- 26.9** The successful bidder will be required to obtain License from the office of the Labour Commissioner for the required strength of labour, before commencement of work at site and the same shall be maintained updated and valid throughout the currency of the contract.
- 26.10** If any amount becomes payable by GMDC as a result of any claim or application in terms of the provisions or non-compliance of provision of any Acts and the Rules and Regulations, By-laws or the Orders made there under, applicable from time to time, such amounts shall be recoverable from the successful bidder for which GMDC will not be responsible for any compensation.
- 26.11** That the successful bidder would obey with all applicable laws and maintain all such necessary records as necessitated under such enactments.
- 26.12** The successful bidder shall also indemnify the GMDC against any claims, compensations, damages, loss, liquidated damages etc. for breach and / or non-fulfillment of the prevailing Rules and Regulations and other statutory provisions in force from time to time and applicable to the work during the currency of contract.
- 26.13** The successful bidder shall abide by the provision of the Motor Vehicle Act for machinery. Any consequences arising out of non-compliance of said Provisions will be at the successful bidder's sole risk and cost, for which GMDC will not be responsible for any compensation.
- 26.14** The successful bidder shall comply with other statutory provisions of Law. The successful bidder shall comply with all applicable laws, ordinances, approved standards, rules and regulations, and shall procure all necessary municipal and governmental permits, licenses and inspection and shall pay all fees and charges in connection with the items covered by the contract. The successful bidder shall serve GMDC harmless as a result of any in factions thereof. The successful bidder will be solely liable for all non-compliances. The following are some of the major Government of India Acts and Regulations to be complied with by the successful bidder. The List is illustrative and not exhaustive.
- 1.** The Factories Act of 1948 (63 to 1948) and Amendments and Rules (Amended up to date)



2. The Electricity Act, 2003 and rules made there under
3. The Indian Boiler Regulation Act, 1950 and rules made there under
4. The Minimum Wages Act, 1948
5. The Employees Compensation Act 1923 and Amendment Act 2010
6. The Payment of Wages Act 1936 and Amendment Act 2012
7. Payment of Bonus Act 1965 and Amended up to date
8. Contract Labour Regulations & Abolition Act 1970
9. Interstate Migrant Workmen (Regulations) Act 1979

27. Termination Of Contract

If at any time during the currency of this contract, if any breach occurs due to the reasons attributed to the Successful bidder, GMDC shall be at liberty to terminate this contract without assigning any reasons, whatsoever, for such termination and any losses and/or damages occurring due to such termination shall be borne by the Successful bidder. GMDC shall be entitled to forfeit Security deposits as Liquidated damages.

28. Governing Law

This Tender and subsequent Contract shall be construed and interpreted in accordance with and governed by the laws of India.

29. Jurisdiction

The matter related to any dispute or difference arising out of this Tender and subsequent contract shall be subject to the exclusive jurisdiction of Court at Ahmedabad only.

30. Arbitration

All questions, disputes, differences whatsoever which may at any time arise between the parties to this Tender and subsequent contract in connection with the Tender and subsequent contract or any matter arising out of or in relation thereto, shall be referred to Sole Arbitrator as per the provisions of Arbitration and Conciliation Act, 1996 and subsequent amendment thereto and the venue of arbitration proceedings shall be at Ahmedabad only. The Language of the Arbitration shall be in English only.



31. Completion Of Work

- 31.1** Upon the Successful bidder fulfilling the entirety of its obligations under the Contract to the satisfaction of GMDC and subject to terms and conditions of the Contract, it shall become eligible to apply for a Completion Certificate. Project Director (ATPS) or The General Manager (Plant) of the GMDC shall formally issue the Completion Certificate, after verifying from the completion documents and satisfying himself that the Works under the Contract have been completed in accordance with all the provisions of this Contract. The Successful bidder, after obtaining the Completion Certificate shall become eligible to present the final bill for the Works executed by it under the Contract.
- 31.2** The Successful bidder shall provide GMDC with any and all documents/records/proofs that may be demanded before issuance of Completion Certificate.
- 31.3** As time is essence of this project, contractor should adhere to duration of contract, except for short fall of raw material in market or delay due to natural calamity.

32. Accident and Responsibilities of Bidder

- 32.1** The entire responsibility on account of any accidents, damage or personal injury which may occurred to any of the Successful bidder's vehicles/ equipment or his/its employees or any outside party shall be exclusively that of the Successful bidder and no claim whatsoever shall be entertain by the GMDC on this account. The Successful bidder shall keep the GMDC indemnified from all the consequence.
- 32.2** In the event of any breakdown or accident during the course of any supply, the Successful bidder shall notify the facts to the GMDC Authority, or any other officer immediately present there of such incidence and shall simultaneously make adequate remedial arrangements on his/its own cost and risk and as per the instruction of the Corporate office Authority.
- 32.3** The Successful bidder shall pay all claims, damages and compensation with cost arising out of or resulting there from to the third party(s) and in case the GMDC would be required to face any proceedings all to pay any amount on the aforesaid account, it shall be deemed to have been discharge on behalf of the Successful bidder, the same amount shall be recovered



half-an hour rest interval in between. The Successful bidder shall ensure that the attendance of all the supplied manpower shall be taken through biometric attendance machine.

33. Foreclosure

In case of any necessity arising due to local working conditions or any unforeseen reason not in the control of the GMDC or any reason what so ever GMDC shall be at liberty to Foreclose the contract without assigning any reasons or notice there for.

34. Force Majeure

Force majeure is herein defined as any cause which is beyond the control of the Successful bidder or the GMDC as the case may be which they could not foresee or with a reasonable amount of diligence could not have foreseen and which substantially affect the performance of the contract, such as:

- 34.1** Natural phenomena such as flood, draughts Cyclone, earthquake and epidemics, declaration of war.
- 34.2** Acts of any government, including but not limited to war, declared or undeclared priorities, quantities, embargoes, providing either party shall within fifteen (15) days from the occurrence of such a cause notify the other in writing of such cases.
- 34.3** The Successful bidder will advise, in the event of his having resort to this clause by a registered letter duly certified by the statutory authorities, the beginning and end of the cause of delay, within fifteen days of the occurrence and cessation of such Force Majeure condition. In the event of delay lasting over two months, if arising out of Force Majeure, the contract may be terminated at the discretion of the GMDC.
- 34.4** For delay arising out of Force Majeure, the Successful bidder will not claim extension in completion date for a period exceeding the period of delay attributable to the causes of force Majeure and neither company nor the Successful bidder shall be liable to pay extra costs (like increase in rates, remobilization, advance, idle charges for labour and machinery etc.) provided it is mutually established that the Force Majeure conditions did actually exist.



- 34.5** If any of the Force Majeure conditions exists in the place of operation of the Successful bidder even at the time of submission of bid, he will categorically specify them in his bid and state whether they have been taken into consideration in their quotations.
- 34.6** The Successful bidder or the GMDC shall not be liable for delays in performing his obligations resulting from any force majeure cause as referred to and/ or defined above. The date of completion will, subject to hereinafter provided, be extended by a reasonable time.



Annexure-A

Instruction to Bidders for Online Tendering

1. All Bidders must submit their bid online through the website <https://gmdctender.nprocure.com>
2. Bidders who wish to participate in online tenders will have to procure / should have legally valid Digital Certificate (Class III) as per Information Technology Act-2000, using which they can sign their electronic bids. Bidders can procure the same from any of the license certifying Authority of India or can contact (n) code solutions- a division of GNFC Limited, who are licensed Certifying Authority by Government of India at address mentioned below at clause 5.
3. All bids should be digitally signed. For details regarding digital signature certificate and related training involved at the below mentioned address should be contacted:

Address:

(n)Procure Cell

(n)Code solutions A division of GNFC

403, GNFC Info-Tower, Bodakdev, Ahmedabad- 380 054 (India)

Tel +91 79- 4000 7300 Fax: +91 79 26857321, Toll Free: 7359021663

E-mail : nprocure@ncode.in

4. Kindly take note that, valid Digital Signature Certificates is a must for all the interested Bidders. Online tendering process is not possible without a valid digital signature certificate.
5. Interested Bidders are also requested to complete their procedure for taking digital signature certificate in respect to filling of application form, supporting documents with necessary fees at least 3 days before last date of tender submission.
6. (n) code solutions reserve the rights to issue digital signature certificate after verification of application forms / supporting documents submitted by Bidder. (n) code solutions is fully authorized to issue digital signature certificate to Bidders.
7. Bidders who have no facility to participate in on-line tenders are requested to contact (n) code solutions for the same.
8. Free vendor training camp will be organized every Saturday between 4.00 to 5.00 P.M. at (n) code solutions-A Division of GNFC Ltd. at address mentioned above. Bidders are requested to take benefit of the same.
9. All the correspondence in respect to training, support or digital signature certificate should be addressed to (n) code solutions directly on the above-mentioned address. In case the Bidders face any difficulty, they may contact the officials of the GMDC or GNFC on the below mentioned details:

a. GMDC:

Contact Person: **Project Director (ATPS)**

**Akrimota Thermal Power Station, Village: Nanicheer, Taluka:lakhapat, District:
Kutch, Gujarat-370601**

E-mail: jndave@gmdcltd.co.in, Website: www.gmdcltd.com

b. GNFC:

Contact Number: 079- 26857316/17/18

E-Mail: nprocure@gnfc.net



Annexure-B

Annexure I.

Finance Department, GR. No.: FD/MSM/e-file/4/2024/2859/D.M.O.

Date: 01/05/2025

(A) Guarantees issued by the following banks will be accepted as SD/EMD on a permanent basis:

❖ **All Nationalized Banks**

(B) Guarantees issued by the following Banks will be accepted as SD/EMD for the period up to March 31, 2026. The validity cut-off date in the GR is with respect to the date of issue of Bank Guarantee irrespective of the date of termination of Bank Guarantee.

| Sr No | Name of Banks | Sr No | Name of Banks |
|-------|----------------------------|-------|---|
| 1 | AXIS Bank | 22 | South Indian Bank |
| 2 | AU Small Finance Bank | 23 | Standard Chartered Bank |
| 3 | Bandhan Bank | 24 | Tamilnad Mercantile Bank |
| 4 | Barclays Bank | 25 | Utkarsh Small Finance Bank |
| 5 | City Union Bank | 26 | YES Bank |
| 6 | CSB Bank | 27 | Ahmedabad Mercantile Co-op. Bank |
| 7 | DBS Bank India Limited | 28 | Nutan Nagrik Sahkari Bank Ltd. |
| 8 | DCB Bank | 29 | Rajkot Nagarik Sahakari Bank Ltd. |
| 9 | Equitas Small Finance Bank | 30 | Saraswat Co-Operative Bank Ltd |
| 10 | ESAF Small Finance Bank | 31 | SBPP Co-operative Bank Ltd. |
| 11 | FEDERAL Bank | 32 | SVC Co-Operative Bank Ltd. |
| 12 | HDFC Bank | 33 | The Cosmos Co-op Bank Ltd. |
| 13 | HSBC Bank | 34 | The Gujarat State Co-operative Bank |
| 14 | ICICI Bank | 35 | The Mehsana Urban Co-Op. Bank |
| 15 | IDBI Bank | 36 | The Surat District Co-op Bank |
| 16 | IDFC First Bank | 37 | The Surat People's Co. Op. Bank Ltd |
| 17 | Jammu and Kashmir Bank | 38 | The Kalupur Commercial Co-op. Bank |
| 18 | Jana Small Finance Bank | 39 | The Panchmahal District Co-operative Bank |
| 19 | Karnataka Bank | 40 | The Baroda District Co-operative Bank |
| 20 | Karur Vysya Bank | 41 | Baroda Gujarat Gramin Bank |
| 21 | Kotak Mahindra Bank | 42 | Saurashtra Gramin Bank |

All the eligible banks are instructed to collect the original documents/papers of guarantee from the concerned tendering authority.

(Arvind V.)

Joint Secretary (Budget)
Finance Department



Annexure-C

Bank of Baroda RTGS slip with a large blue 'CANCELLED' stamp. The slip includes the following details:

- Pay:** Rupees १५००००००
- Account No. (A/C. No.):** 90580400000264
- IBAN:** IN000774331370012546140026429
- RTGS / NEFT IFSC CODE:** BARB00BPDR0
- Branch:** PANANDHRO BRANCH, PANANDHRO 370801
- Account Type:** CBS (Current Bank Savings)
- Account Category:** D (Demand)
- Signature:** [Blank]
- Stamp:** CANCELLED FOR GUJARAT MINARALS DEVELOPMENT CORPORATION

Bank Details for RTGS



FORM-PA

CHECK LIST OF DOCUMENTS ENCLOSED WITH TENDER

TECHNICAL BID

| Sr. No. | Document | Declaration (Strike out whichever is not applicable) |
|----------------|--|---|
| 1. | Tender Processing Fee | Yes/No |
| 2. | EMD | Yes / No |
| 3. | Form PA (check list of documents enclosed with tender) | Yes / No |
| 4. | Form PB (Status of the Bidder) | Yes / No |
| 5. | Form PC (CA Certification for Financial Details and work carried out during the last seven years of bidder) | Yes / No |
| 6. | Form PD (Declarations) | Yes / No |
| 7. | Form PE (Undertaking of Genuineness of Document) | Yes / No |
| 8. | Form PF (Undertaking of Indemnity) | Yes / No |
| 9. | Form PG (Site Visit) | Yes / No |
| 10. | Power of Authority to sign the documents (Duly Notarized on Stamp paper of Rs. 300) | Yes / No |

PRICE BID

| | | |
|----------|---|----------|
| 1 | Online Price bid submission in Form PP | Yes / No |
|----------|---|----------|



FORM-PB STATUS OF THE BIDDER

| Particulars | Details |
|--|----------------|
| Name of the Bidder: | |
| Address: | |
| Registered office: | |
| For correspondence: | |
| Telephone No. | |
| Fax No. | |
| E-mail Address | |
| Attested copies of Deeds, Articles of association to be enclosed | |
| Name & contact number of person holding power of attorney (Attested copy of power of attorney to be enclosed) | |
| Names of Partners with their Present and permanent address | |
| Name of Bankers with full address and Telephone No& Bank Account Details (Cancelled Cheque to be enclosed) | |
| PAN of Bidder | |
| GST Registration No. of Bidder | |
| PF Registration No. | |
| Whether enlisted in other dept., if yes, then furnish the details pertaining to class and the amount qualified to tender | |
| Was the applicant or its partners or Directors blacklisted in past by any Govt. or any other body. | |
| Details pertaining to the work incomplete if any | |
| Details of the litigation, court cases and arbitration either completed or under progress during last 10 years by the GMDC entity or any partner/proprietor of present entity GMDC was associated in any capacity. | |

Signature and Stamp of the Bidder



FORM-PC

1. Turnover and Net Worth

On the basis of the **audited books of accounts** produced before us by M/s. _____, we certify that as per the books of account Net worth and Turn Over of the firm M/s _____ are as under:

1.1 Net Worth= Rs. _____ for the Year ended on 31.03.2023.
 Rs. _____ for the Year ended on 31.03.2024.
 Rs. _____ for the Year ended on 31.03.2025.

Average Net Worth Rs. _____

1.2 Turn Over = Rs. _____ for the Year ended on 31.03.2023.
 Rs. _____ for the Year ended on 31.03.2024.
 Rs. _____ for the Year ended on 31.03.2025.

Average Turnover of Rs. _____

2. Details of Work Carried Out During the Last Seven Years by the Bidder (i.e. period from 01.04.2018 to 31.03.2025):

| Sr. No. | Description of work with Workplace | Name of client with postal address | Work Order number and date | Contract Period | | Actual Quantity worked | Amount without GST of work order | Work experience certificate attached |
|---------|------------------------------------|------------------------------------|----------------------------|-----------------|-----------|------------------------|----------------------------------|--------------------------------------|
| | | | | From (Date) | To (Date) | | | |
| | | | | | | | | Yes/No |
| | | | | | | | | Yes/No |
| | | | | | | | | Yes/No |
| | | | | | | | | Yes/No |

Signature and Stamp of the Bidder

Signature and Stamp of the CA



FORM-PD

Declaration

(On letter head of the Bidder)

DATE:

To,

**Project Director (ATPS)
Akrimota Thermal Power Station,
Village: Nanicheer,
Taluka:lakhapat,
District: Kutch, Gujarat-370602**

Dear Sir,

I/we here by solemnly declare that

1. Any of our Directors or Partners, jointly or severally and/or individually or our firm/GMDC have not been black listed by the Central Govt. or the State Govt. or its undertakings.
2. We have not put any condition in our offer with respect to Tender No. _____,
3. We have accepted all the terms and conditions, including Annexure, Corrigendum if any, as specified in the Tender Document No. _____ unconditionally.

I/we here by further declare that, if the declaration is found untrue, the GMDC shall be entitled to take any action against us severally and/or individually or our firm/GMDC in this regard in any manner that may be deemed fit by GMDC.

Yours faithfully,

Signature and Stamp of the Bidder



FORM -PE

(Format for Affidavit)

A F F I D A V I T

**Undertaking Regarding Geniuses of Documents
(On Non-Judicial Stamp Paper of Rs 300/-)**

I/We, _____, Partner/Director/Legal Attorney/Accredited
Representative of M/s. _____ solemnly declare that:

1. I/We are submitting Tender for the work _____
_____ against Tender No. _____
2. None of the Partners/Directors of our firm/GMDC is relative of employee of GMDC.
3. All information furnished by us in respect of fulfillment of eligibility criteria and qualification information of this Tender is complete, correct and true.
4. All documents/credentials submitted along with this Tender are genuine, authentic, true and valid.
5. If it is found at any point of time that our documents are not genuine then in that case our tender will be rejected, earnest money deposited by us will be forfeited and we will be debarred from participating in further/future GMDC tenders and/or any action as deemed fit by GMDC may be taken against us, including termination of the contract, forfeiture of all dues including Earnest Money / Security deposit and banning/delisting of our entity and all related persons etc.

**SIGNATURE OF THE BIDDER
WITH SEAL**

Dated



FORM-PF

Undertaking Of Indemnity
(On Letter head of the Bidder)

To,

Project Director (ATPS)
Akrimota Thermal Power Station,
Village: Nanicheer,
Taluka:lakhapat,
District: Kutch, Gujarat-370602

Dear Sir,

We M/s. ----- hereby undertake that, we shall at all times, indemnify and keep indemnified that GMDC Limited from any and all liability for damages resulting from or arising out of or in any way connected with the operations covered by the Tender No. _____. We shall be responsible for all risk arising in connection with or on account of the operations covered by the contract covered by the above tender and shall make good all losses and damages arising there from. In case, the GMDC Limited shall incur any cost or expense or suffer any loss on account of any claim demand or course of action brought against us and arising out of the operations covered by the Bidder/tender, the GMDC Limited shall have the power (without being bound to do so) to define, contest or compromise any such claim demand or cause of action. Any amount that may become payable by GMDC Limited and any cost expense etc. that may be incurred by the GMDC Limited in this behalf, shall also be recoverable from us, without prejudice to your other rights.

Yours faithfully,

For -----

(Signature & Stamp of the Bidder)



FORM-PG

Declaration

(On letter head of the Bidder)

Site Visit

We _____ hereby certify that we have fully understood the site condition in respect of Tender No. _____ for all the works mentioned above at _____. We have obtained all relevant details, information, data, existing working conditions, existing industrial environment etc. We have also studied the working conditions as proposed in the tender and availability of power supply, water supply, manpower, machineries, transportation facility etc.

We hereby agree and undertake not to raise any dispute and/or objection at any stage on any ground whatsoever, during the currency of the contract if awarded to us.

SIGNATURE OF THE BIDDER WITH SEAL

Dated



FORM-PP

**PRICE BID FORM
(To be submitted online)**

Sub.: - Work of Supply of Soot Blower Mechanical spares for CFBC Boiler at GMDC's 2x125 MW Akrimota Thermal Power Station

| Sr.No. | Area | Item description | UOM | Qty. | Unit rate (in INR) (Excluding GST) | Total Amount (in INR) (Excluding GST) |
|--------|-------------|--|------|------|---|---|
| 1 | SOOT BLOWER | GRUB SREW,M10X30MM,HT,APPLICATION-SOOT BLOWER | NOS. | 20 | | |
| 2 | SOOT BLOWER | OIL SEAL 38 X 58 X 10MM | NOS | 20 | | |
| 3 | SOOT BLOWER | BEARING 6002/C2 | NOS | 20 | | |
| 4 | SOOT BLOWER | WOOL RUF KEY,PART NO.350549015,MODEL NO.IK-300, MAKE:ALSTOM,FOR GEAR COTE OTSEMBLY OF SOOT BLOWER | NOS | 8 | | |
| 5 | SOOT BLOWER | WOOD RUF KEY,PART NO.606,MODEL NO.IK-300, MAKE:ALSTOM,FOR GEAR COTE OTSEMBLY OF SOOT BLOWER | NOS | 8 | | |
| 6 | SOOT BLOWER | GASKET,PART NO.350501347, DRG NO.30656-0,MOC:MONEL SS,MODEL NO.IK-300,MAKE:ALSTOM,FOR SOOT BLOWER | NOS | 10 | | |
| 7 | SOOT BLOWER | GUIDE VALVE STEM,PART NO.350502510,DRG NO.302031-0110(SB-80),MODEL NO.IK-300, MAKE:ALSTOM,FOR POPPET VALVE ASSEMBLY OF SOOT BLOWER | NOS | 6 | | |
| 8 | SOOT BLOWER | PACKING WASHER, PART NO.35050284, MAKE : ALSTOM, FOR SOOT BLOWER | NOS | 6 | | |
| 9 | SOOT BLOWER | VALVE SPRING,PART NO.350502543,DRG NO.302051-0115,MODEL NO.IK-300, MAKE:ALSTOM,FOR POPPET VALVE ASSEMBLY OF SOOT BLOWER | NOS | 6 | | |
| 10 | SOOT BLOWER | STEM AND DISC ASSEMBLY,PART NO.350503284,DRG NO.309964-1023(178),MODEL NO.IK-300, MAKE:ALSTOM,FOR POPPET VALVE ASSEMBLY OF SOOT BLOWER | NOS | 8 | | |
| 11 | SOOT BLOWER | TRIGGER PIN,PART NO.350500038,DRG NO.301158-0119,MODEL NO.IK-300, MAKE:ALSTOM,FOR POPPET VALVE ASSEMBLY OF SOOT BLOWER | NOS | 10 | | |
| 12 | SOOT BLOWER | COTTER PIN,PART NO.3505010063,MODEL NO.IK-300, MAKE:ALSTOM,FOR POPPET VALVE ASSEMBLY OF SOOT BLOWER | NOS | 10 | | |
| 13 | SOOT BLOWER | VALVE STEM PACKING,PART NO.350502521,DRG NO.302034-0117(SB-82),MODEL NO.IK-300, MAKE:ALSTOM,FOR POPPET VALVE ASSEMBLY OF SOOT BLOWER | NOS | 10 | | |



| | | | | | | |
|----|--------------------|--|-----|----|--|--|
| 14 | SOOT BLOWER | VALVE SPRING RETAINER,PART NO.350502851,DRG NO.301808-0113,MODEL NO.IK-300, MAKE:ALSTOM,FOR POPPET VALVE ASSEMBLY OF SOOT BLOWER | NOS | 10 | | |
| 15 | SOOT BLOWER | VALVE YOKE,PART NO.350502667,DRG NO.301142-0118(SB-70),MODEL NO.IK-300, MAKE:ALSTOM,FOR POPPET VALVE ASSEMBLY OF SOOT BLOWER | NOS | 10 | | |
| 16 | SOOT BLOWER | YOKE PIN,PART NO.350500060,MODEL NO.IK-300, MAKE:ALSTOM,FOR POPPET VALVE ASSEMBLY OF SOOT BLOWER | NOS | 10 | | |
| 17 | SOOT BLOWER | SEAT FLEXIBLE,PART NO.350504184,DRG NO.310666-2129(SB-835),MODEL NO.IK-300, MAKE:ALSTOM,FOR POPPET VALVE ASSEMBLY OF SOOT BLOWER | NOS | 10 | | |
| 18 | SOOT BLOWER | TRIP STUD,PART NO.350500351,MODEL NO.IK-300,DRG NO.305674-0115G(SB135) MAKE:ALSTOM,FOR POPPET VALVE ASSEMBLY OF SOOT BLOWER | NOS | 10 | | |
| 19 | SOOT BLOWER | CAM ASSEMBLY,PART NO.3505000351,MODEL NO.IK-300, MAKE:ALSTOM,FOR POPPET VALVE ASSEMBLY OF SOOT BLOWER | NOS | 6 | | |
| 20 | SOOT BLOWER | COTTER PIN ,PART NO.8636071934,MODEL NO.G9B, MAKE:ALSTOM,FOR ROTARY GOOSE NECK ASSEMBLYOF SOOT BLOWER | NOS | 6 | | |
| 21 | SOOT BLOWER | VALVE STEM PACKING,PART NO.3020340117,MODEL NO.IK-300,MAKE:ALSTOM,FOR SOOT BLOWER | NOS | 5 | | |
| 22 | SOOT BLOWER | VALVE YOKE,MAKE:ALSTOM,FOR SOOT BLOWER | NOS | 5 | | |
| 23 | SOOT BLOWER | VALVE YOKE PIN,PART NO.3091870117,MAKE:ALSTOM,FOR SOOT BLOWER | NOS | 5 | | |
| 24 | SOOT BLOWER | THRUST BALL BEARING,DRG NO.301213-1011J(824),MODEL NO.IK-300,MAKE:ALSTOM,FOR SOOT BLOWER | NOS | 4 | | |
| 25 | SOOT BLOWER | DEEP GROOVE NON FILLING SLOT BALL BEARING,PART NO.3E0540145,MAKE:ALSTOM,FOR SOOT BLOWER | NOS | 4 | | |
| 26 | SOOT BLOWER | INNER AND OUTER BEARING,PART NO.3505010056,MAKE:ALSTOM,FOR SOOT BLOWER | NOS | 10 | | |
| 27 | SOOT BLOWER | OIL SEAL,DRG NO.904532-0001,MAKE:ALSTOM,FOR SOOT BLOWER | NOS | 6 | | |
| 28 | SOOT BLOWER | NEEDLE ROLLER BEARING,PART NO.416592077,MODEL NO.IK-300,MAKE:ALSTOM,FOR SOOT BLOWER | NOS | 10 | | |
| 29 | SOOT BLOWER | TRIGGER ASSEMBLY,PART NO.3505010067,MODEL NO.G9B, MAKE:ALSTOM,FOR ROTARY SOOT BLOWER | NOS | 6 | | |
| 30 | SOOT BLOWER | SWIVEL TUBE,PATR NO.3E0540065,MODEL NO.G9B, MAKE:ALSTOM,FOR SOOT BLOWER | NOS | 6 | | |



| | | | | | | |
|-------|--------------------|---|-----|---|--|--|
| 31 | SOOT BLOWER | VALVE YOKE PIN,PART NO.309187,MODEL NO.IK-300,MAKE-ALSTOM,APPLICATION-SOOT BLOWER | NOS | 4 | | |
| 32 | SOOT BLOWER | OPERATING LEVER FOR POPPET VALVE , MODEL -IK300, APPLICATION-SOOT BLOWER | NOS | 4 | | |
| TOTAL | | | | | | |

Note:

1. **Quoted Price shall be inclusive of all other Taxes and exclusive of GST.**
2. **Bidders are requested to quote the rates strictly as per the terms and conditions mentioned in the Tender Document. Rate quoted by the bidder should be firm and no price increase will be allowed to the successful bidder during the supply period.**
3. **The bidder should quote price only on free delivery at our Project basis. The rates other than (FOR project basis) (our project basis) will not be considered.**
4. **Supply of all the material as per required quantity will be in scope of successful bidder, etc.) for items listed in BOQ of this tender to complete the job will be under Bidder's scope.**



Format for e-Bank Guarantee towards EMD

Please note the following details for Compulsory e-confirmation for Bank Guarantee through ICICI Bank through SFMS under our:

Gujarat Mineral Development Corporation Limited (GMDC)
Akrimota Thermal Power Station,
Village: Nanichher,
Taluka: Lakhapat,
District: Kutch,
Gujarat-370602

Bank Name: Bank of Baroda, Panandhro,
Ta. Lakhapat, Kutch-370601,
Account Number: 90580400000264
IFSC: BARB0DBPDRO

(On Non-judicial Stamp paper to be submitted along with submission of bids)

..... (Name of the Bank)
Address.....
Guarantee No.....
A/C Messrs..... (Name of Bidder)
Date of Expiry.....
Limit to liability (currency & amount)
Invitation for RFP No..... Dated..... (Bidding document)
For..... (Name of Facilities)

Subject: Earnest Money Deposit Bank Guarantee.

Date.....2024



To,

Gujarat Mineral Development Corporation Limited (GMDC)
Akrimota Thermal Power Station,
Village: Nanichher,
Taluka: Lakhapat,
District: Kutch,
Gujarat-370602

Dear Sir,

In consideration of Gujarat Mineral Development Corporation (hereinafter called “GMDC”) which expression shall unless repugnant to the subject of context include his successors and assigns having agreed to exempt M/s..... (herein after called “Bidder”) from demand under the terms and conditions of “Technical Bid Document” (hereinafter called the said “Bidding Document”) issued by the GMDC vide RFP No. _____ for the work _____

(Name of the facilities) from Earnest Money Deposit (EMD) of Bid for the due fulfillment by the Bidder of the terms and conditions contained in the said Bidding Document on production of Bank Guarantee for INR _____ (_____ only) (figure in words).

- 1** We the _____ (Name of Bank) hereinafter referred to as “Bank” having our registered office at _____ (address of Bank) do hereby undertake and agree to indemnify and keep indemnified GMDC to extent of INR _____ (_____ only) (figures in words) against any losses, damage cost, charges and expenses caused to or suffered by or that may be caused or suffered by GMDC by reason of any breach or breaches by the Bidder of any of the terms and conditions contained in the said Bidding Document and unconditionally pay the amount claimed by GMDC on demand and without demur to the extent aforesaid.
- 2** We _____ (Name of Bank) do hereby undertake to pay the amounts due and payable under the guarantee without any demur merely on a demand by you stating that the amount claimed is due by way of loss or damage caused to or would be caused or suffered by you by reason of any breach by the said Bidder of any of the terms or conditions contained in the said Bidding Document by reason of the Bidder’s failure to fulfill the conditions of said Bidding Document. Any such demand on the Bank shall be conclusive as regards the amount due and payable by the Bank under this guarantee. However, our liability under this guarantee shall be restricted to an amount not exceeding INR _____.
- 3** We _____ (Name of Bank) further agree that GMDC shall be the sole judge of and as to whether the Bidder has committed any breach or breaches of terms and conditions of the said Bidding Document and the extent of loss, damages, costs, charges and expenses caused



to or suffered by or that may cause to or suffered by GMDC on account hereof to the extent of the Bid Security required to be deposited by the Bidder in respect of the said document and the decision of GMDC that the Bidder has committed such breach or breaches and as to the amount or amounts of loss, damages, costs, charges, and expenses caused to or suffered by or that may be caused to or suffered by GMDC shall be final and binding on us.

- 4** We _____ (Name of Bank) further agree that guarantee herein contained shall remain in full force and effect during the period that would be taken for the performance on the said Bidding Document and that it shall continue to be enforceable till you certify that terms and conditions of the said Bidding Document have been fully and properly carried out by the said Bidder and accordingly discharge the guarantee. Unless a demand or claim under this guaranteed is made on us in writing on or before the (date) _____ we shall be discharged from all liability under this guarantee.
- 5** We _____ (Name of Bank) further agree with you that you have the fullest liberty without our consent and without affecting in any manner our obligations hereunder to vary any of the terms and conditions of the said Bidding Document or to extend time of performance by the said Bidder from time to time or to postpone for any time or from time to time any of the powers exercisable by you against the said Bidder and to forbear or enforce any of the terms and conditions relating to the said Bidding Document and we shall not be relieved from our liability by reason of any such variation or extension being granted to the said Bidder or for any forbearance act or omission on your part or any indulgence by you to the said Bidder or any such matter or thing whatsoever under the law relating to sureties would but for this provision have effect of so relieving us.
- 6** It shall not be necessary for GMDC to proceed against the Bidder before proceeding against the Bank and the Guarantee herein contained shall be enforceable against the Bank, notwithstanding any security which GMDC may have obtained from the Bidder at this time when proceeding is taken against Bank hereunder be outstanding or unrealized.
- 7** We _____ (Name of Bank) further undertake to unconditionally pay the amount claimed by GMDC merely on demand and without demur to the extent aforesaid.
- 8** We, the said Bank lastly undertake not to revoke this guarantee during its currency except with the previous consent of GMDC in writing.
- 9** This Guarantee will not be discharged due to the change in the constitution of the Bank or the said Bidder.
- 10** The Bank has under its constitution power to give this guarantee and Mr. _____ who has signed it on behalf of the Bank have authority to do so.

Yours faithfully

For.....
(Name of the Bank)



Notwithstanding anything contained hereinabove

- (I) Our liability under this Bank Guarantee shall not exceed **Rs** _____/- (**Rupees** _____ **only**)
- (II) This Bank Guarantee is valid up to _____ (Date).
- (III) We are liable to pay the guaranteed amount or any part thereof under this bank Guarantee only and only if you serve upon us a written claim or a demand on or before _____(date).
- (IV) This bank guarantee is operative only when accompanied with SFMS advice from us.

Yours faithfully

For _____

(Name of the Bank)

Yours faithfully

For.....

(Name of the Bank)



FORMAT OF e-BANK GUARANTEE FOR SECURITY DEPOSIT (SD)

Please note the following details for Compulsory e-confirmation for Bank Guarantee through ICICI Bank through SFMS under our:

Gujarat Mineral Development Corporation Limited (GMDC)
Akrimota Thermal Power Station,
Village: Nanichher,
Taluka: Lakhapat,
District: Kutch,
Gujarat-370602

Bank Name: Bank of Baroda, Panandhro,
Ta. Lakhapat, Kutch-370601,
Account Number: 90580400000264
IFSC: BARB0DBPDRO

(On Non-judicial Stamp paper to be submitted along with submission of bids)

..... (Name of the Bank)
Address.....
Guarantee No.....
A/C Messrs..... (Name of Bidder)
Date of Expiry.....
Limit to liability (currency & amount)
Invitation for Tender No..... Dated..... (Bidding document)
For..... (Name of Facilities)

Subject: Security Deposit Bank Guarantee.

Date.....20



To,
Gujarat Mineral Development Corporation Limited (GMDC)
Akrimota Thermal Power Station,
Village: Nanichher,
Taluka: Lakhapat,
District: Kutch,
Gujarat-370602

Dear Sir,

In consideration of Gujarat Mineral Development Corporation (hereinafter called "GMDC") which expression shall unless repugnant to the subject of context include his successors and assigns having agreed to exempt M/s..... (herein after called "Bidder") from demand under the terms and conditions of "Technical Bid Document" (hereinafter called the said "Bidding Document") issued by the GMDC vide Tender No. _____ for the work _____

(Name of the facilities) from Security Deposit (SD) of Bid for the due fulfillment by the Bidder of the terms and conditions contained in the said Bidding Document on production of Bank Guarantee for INR _____

(_____ only) (figure in words).

11 We the _____ (Name of Bank) hereinafter referred to as "Bank" having our registered office at _____ (address of Bank) do hereby undertake and agree to indemnify and keep indemnified GMDC to extent of INR _____ (_____ only) (figures in words) against any losses, damage cost, charges and expenses caused to or suffered by or that may be caused or suffered by GMDC by reason of any breach or breaches by the Bidder of any of the terms and conditions contained in the said Bidding Document and unconditionally pay the amount claimed by GMDC on demand and without demur to the extent aforesaid.

12 We _____ (Name of Bank) do hereby undertake to pay the amounts due and payable under the guarantee without any demur merely on a demand by you stating that the amount claimed is due by way of loss or damage caused to or would be caused or suffered by you by reason of any breach by the said Bidder of any of the terms or conditions contained in the said Bidding Document by reason of the Bidder's failure to fulfill the conditions of said Bidding Document. Any such demand on the Bank shall be conclusive as regards the amount due and payable by the Bank under this guarantee. However, our liability under this guarantee shall be restricted to an amount not exceeding INR _____.

13 We _____ (Name of Bank) further agree that GMDC shall be the sole judge of and as to whether the Bidder has committed any breach or breaches of terms and conditions of the said Bidding Document and the extent of loss, damages, costs, charges and expenses caused to or suffered by or that may be caused to or suffered by GMDC on account hereof to the extent of the Bid Security required to be deposited by the Bidder in respect of the said document and the decision of GMDC that the Bidder has committed such breach or breaches and as to the amount or amounts of loss, damages, costs, charges, and expenses caused to or suffered by or that may be caused to or suffered by GMDC shall be final and binding on us.



- 14** We _____ (Name of Bank) further agree that guarantee herein contained shall remain in full force and effect during the period that would be taken for the performance on the said Bidding Document and that it shall continue to be enforceable till you certify that terms and conditions of the said Bidding Document have been fully and properly carried out by the said Bidder and accordingly discharge the guarantee. Unless a demand or claim under this guaranteed is made on us in writing on or before the (date) _____ we shall be discharged from all liability under this guarantee.
- 15** We _____ (Name of Bank) further agree with you that you have the fullest liberty without our consent and without affecting in any manner our obligations hereunder to vary any of the terms and conditions of the said Bidding Document or to extend time of performance by the said Bidder from time to time or to postpone for any time or from time to time any of the powers exercisable by you against the said Bidder and to forbear or enforce any of the terms and conditions relating to the said Bidding Document and we shall not be relieved from our liability by reason of any such variation or extension being granted to the said Bidder or for any forbearance act or omission on your part or any indulgence by you to the said Bidder or any such matter or thing whatsoever under the law relating to sureties would but for this provision have effect of so relieving us.
- 16** It shall not be necessary for GMDC to proceed against the Bidder before proceeding against the Bank and the Guarantee herein contained shall be enforceable against the Bank, notwithstanding any security which GMDC may have obtained from the Bidder at this time when proceeding are taken against Bank hereunder be outstanding or unrealized.
- 17** We _____ (Name of Bank) further undertake to unconditionally pay the amount claimed by GMDC merely on demand and without demur to the extent aforesaid.
- 18** We, the said Bank lastly undertake not to revoke this guarantee during its currency except with the previous consent of GMDC in writing.
- 19** This Guarantee will not be discharged due to the change in the constitution of the Bank or the said bidder.
- 20** The Bank has under its constitution power to give this guarantee _____ and _____ Mr. _____ who has signed it on behalf of the Bank have authority to do so.

Yours faithfully

For.....

(Name of the Bank)

Notwithstanding anything contained hereinabove

- (V) Our liability under this Bank Guarantee shall not exceed **Rs** _____ /- (**Rupees** _____ **only**)
- (VI) This Bank Guarantee is valid up to _____ (Date).
- (VII) We are liable to pay the guarantee amount or any part thereof under this bank Guarantee only and only if you serve upon us a written claim or a demand on or before _____ (date).
- (VIII) This bank guarantee is operative only when accompanied with SFMS advice from us.



Yours faithfully

For.....

(Name of the Bank)



ANNEXURE-I

Soot Blower-G9B

GOOSENECK ASSEMBLY (60 Bar)

22

DRG. NO. 395916-0049
PART NO.

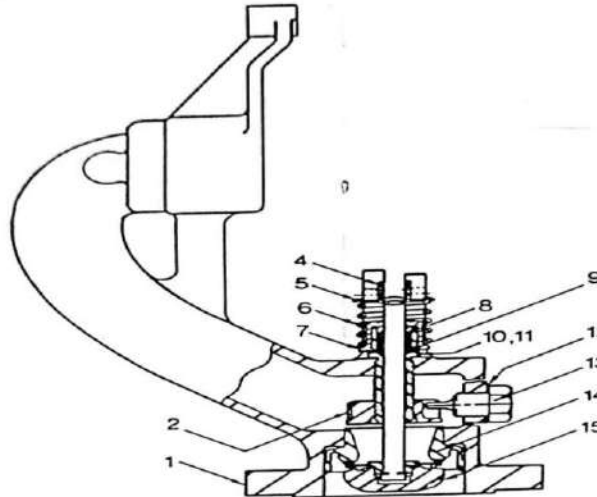

| Item No. | Part No. | Description | No.Off |
|----------|-------------|-----------------------|--------|
| *1 | | Gooseneck | 1 |
| 2 | 394197-1123 | Pressure Control Disc | 1 |
| 4 | 301142-0118 | Valve Yoke | 1 |
| 5 | 301808-0113 | Valve Spring Retainer | 1 |
| 6 | 302051-0115 | Valve Spring | 1 |
| 7 | 302032-0119 | Packing Nut | 1 |
| 8 | 302027-0116 | Packing Washer | 1 |
| 9 | 302034-0117 | Valve Stem Packing | 1 |
| 10 | 302031-0110 | Valve Stem Guide | 1 |
| 11 | 301167-0118 | Valve Guide Washer | 1 |
| 12 | 930711-9034 | Lock Pin Washer | 1 |
| 13 | 393802-1122 | Lock Pin Plug | 1 |
| **14 | 310666-1121 | Flexible Valve Seat | 1 |
| 15 | 309964-2021 | Valve Stem and Disc | 1 |

- Supplied only as a sub-assembly, Part Number 395916- comprising items 1, 2, 10, 11, 12, 13, and 14.
- Oversize valve seats, Part Number 310666-2129, are recommended as service replacements.

MARCH 1988

FORM 13708



SWIVEL TUBE & BRACKET ASSLY.
~~BRACKET AND PLATE ASSEMBLY~~
 (One Piece Swivel Tube)

DRG. NO. 391151-1032
 PART NO.

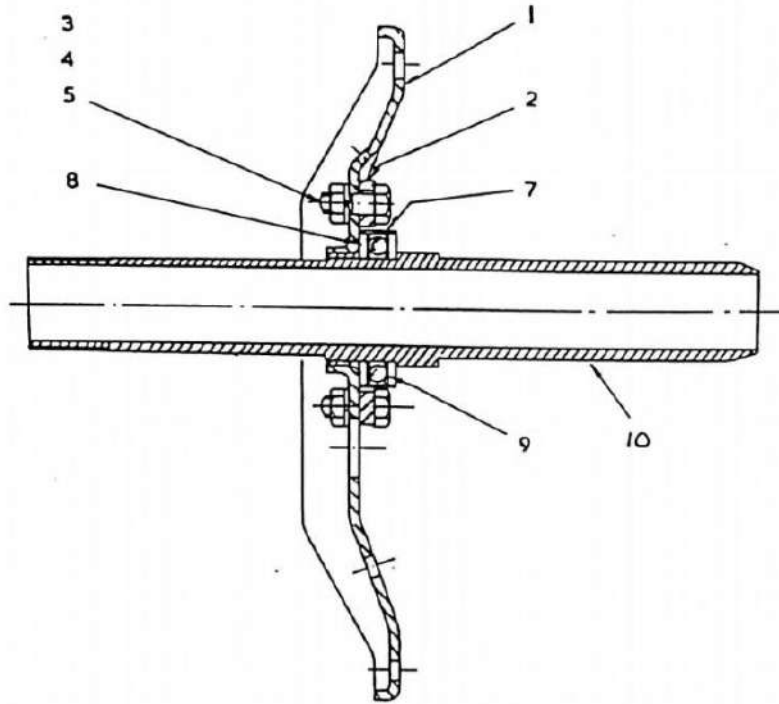

| Item No. | Part No. | Description | No. Off |
|----------|-------------|----------------------------|------------------|
| 1 | | Bracket and Bushing Arrg't | 1 |
| 2 | | Adaptor Plate | 1 |
| 3 | 865005-2734 | Cap Screw | 3 |
| 4 | 863015-2900 | Nut | 3 |
| 5 | 869016-2900 | Lockwasher | 3 |
| 7 | 302069-0115 | Dust Shield Ring | 1 |
| 8 | 301209-0118 | Thrust Washer | 2 |
| 9 | 301213-1011 | Thrust Ball Bearing Arrg't | 1 |
| 10 | | Swivel Tube | 1 <i>1370105</i> |



ELECTRIC MOTOR DRIVE ASSEMBLY

DRG. NO. 392744-1042
PART NO.

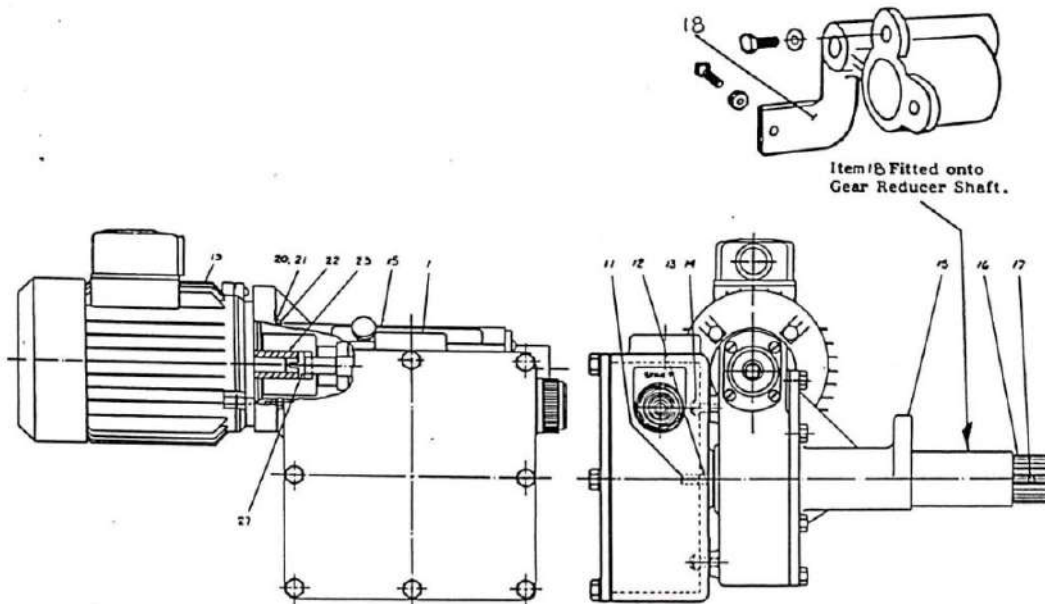

| Item No. | Part No. | Description | No. Off |
|----------|-------------|-------------------------------|---------|
| 1 | | Electric Control Box Assembly | 1 |
| 11 | 302126-0116 | Pinion - 3 teeth | 1 |
| 12 | 863651-1918 | Roll Pin | 1 |
| 13 | 865602-2520 | Screw | 3 |
| 14 | 841413-0001 | Nylite Seal | 3 |
| 15 | | Gear Reducer Assembly | 1 |
| 16 | 301238-0113 | Pinion & Teeth | 1 |
| 17 | 863631-2224 | Pin | 1 |
| 18 | 302147-1010 | Drive Bracket Assembly | 1 |
| 19 | | Motor | 1 |
| 20 | 879007-3200 | Washer | 4 |
| 21 | 879017-3200 | Lockwasher | 4 |
| 22 | 875648-3220 | Bolt | 4 |
| 23 | 395361-1021 | Coupling | 1 |
| 27 | 395078-1124 | Drive Key | 1 |

HEAD ASSEMBLY ()

DRG. NO. 395892-0047
PART NO.

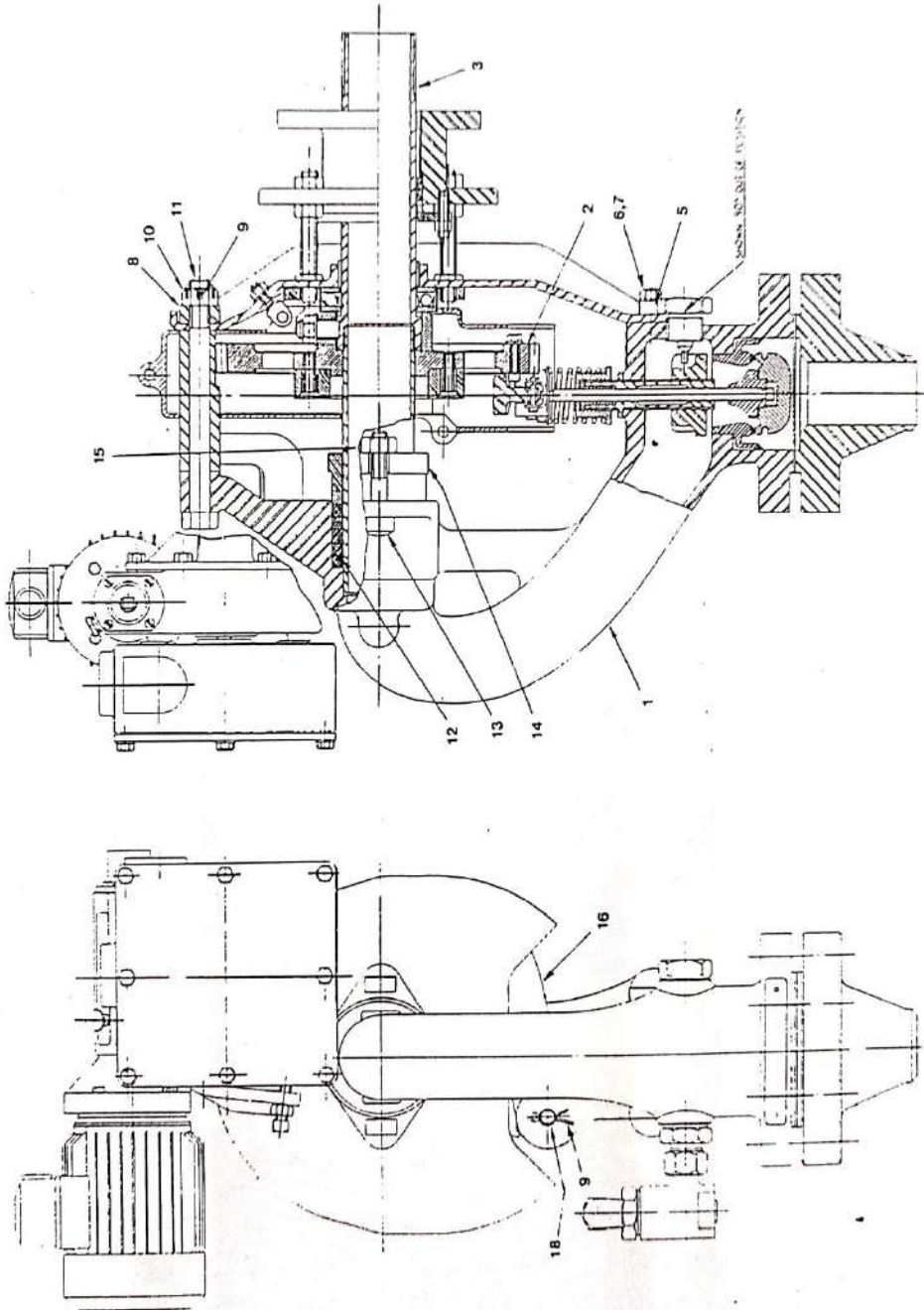



HEAD ASSEMBLY

| Item No. | Part No. | Description | No.Off |
|----------|-------------|----------------------------------|--------|
| 1 | | Gooseneck Assembly | 1 |
| 2 | | Gear & Cam assembly | 1 |
| 3 | | Swivel Tube and Bracket Assembly | 1 |
| 5 | 302062-0112 | Lower Distance Piece | 2 |
| 6 | 865025-2936 | Cap Screw | 2 |
| 7 | 869016-2900 | Lock Washer | 2 |
| 8 | 302129-0113 | Spacer | 1 |
| 9 | 863607-1934 | Cotter Pin | 2 |
| 10 | 863017-3100 | Nut | 1 |
| 11 | 301718-1110 | Tie Bolt | 1 |
| 12 | 310578-1110 | Packing | 1 |
| 13 | 302078-0114 | 'T' Bolt | 2 |
| 14 | 302045-0122 | Gland | 1 |
| 15 | 863008-2900 | Jam Nut | 2 |
| 16 | 395894-000A | Trigger with Yoke pin | 1 |
| 18 | 301158-0119 | Trigger pin | 1 |

1370043

GEAR AND CAM ASSEMBLY

DRG. NO. 395996-0042
PART NO.

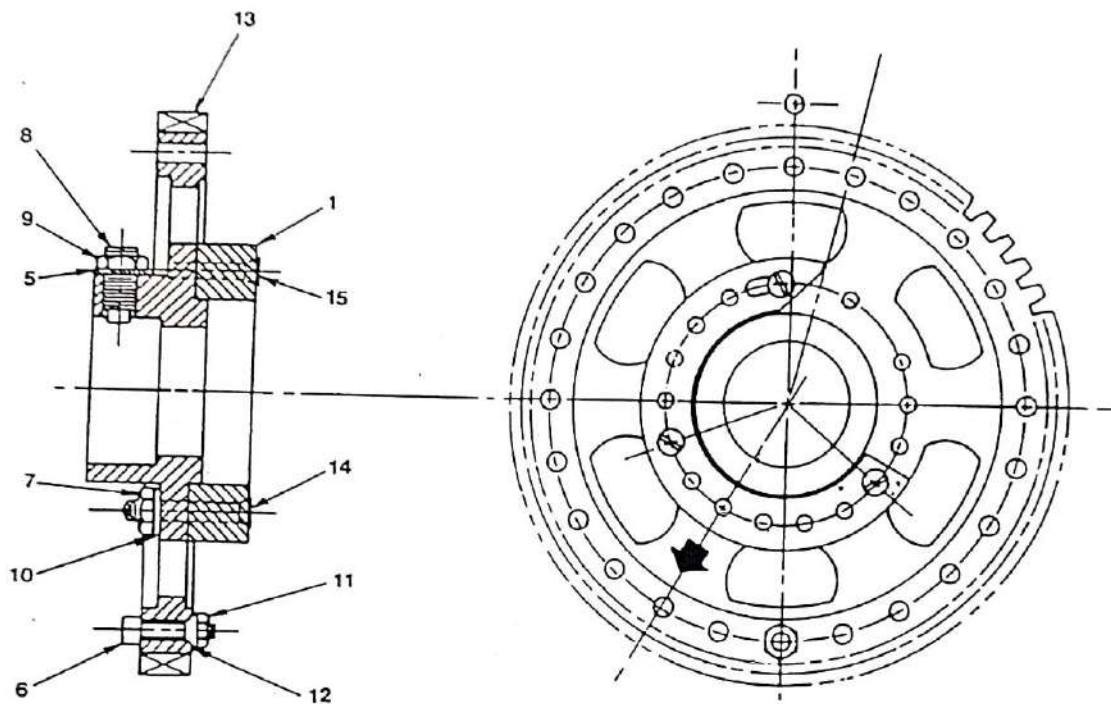

| Item No. | Part No. | Description | No. Off |
|----------|-------------|-------------|---------|
| 1 | | Cam | 1 |
| 5 | 869011-3100 | Lockwasher | 1 |
| 6 | 863651-2732 | Lift Pin | 1 |
| 7 | 863015-2700 | Nut | 3 |
| 8 | 866005-3134 | Set Screw | 1 |
| 9 | 863008-3100 | Jam Nut | 1 |
| 10 | 869011-2700 | Lockwasher | 3 |
| 11 | 863006-2600 | Jam Nut | 1 |
| 12 | 869011-2600 | Lockwasher | 1 |
| 13 | 395995-1132 | Gear | 1 |
| 14 | 865003-2740 | Cap Screw | 3 |
| 15 | 865003-2734 | Cap Screw | 1 |

BRACKET ASSEMBLY

DRG. NO. 302147-1010
PART NO. 302147-1010

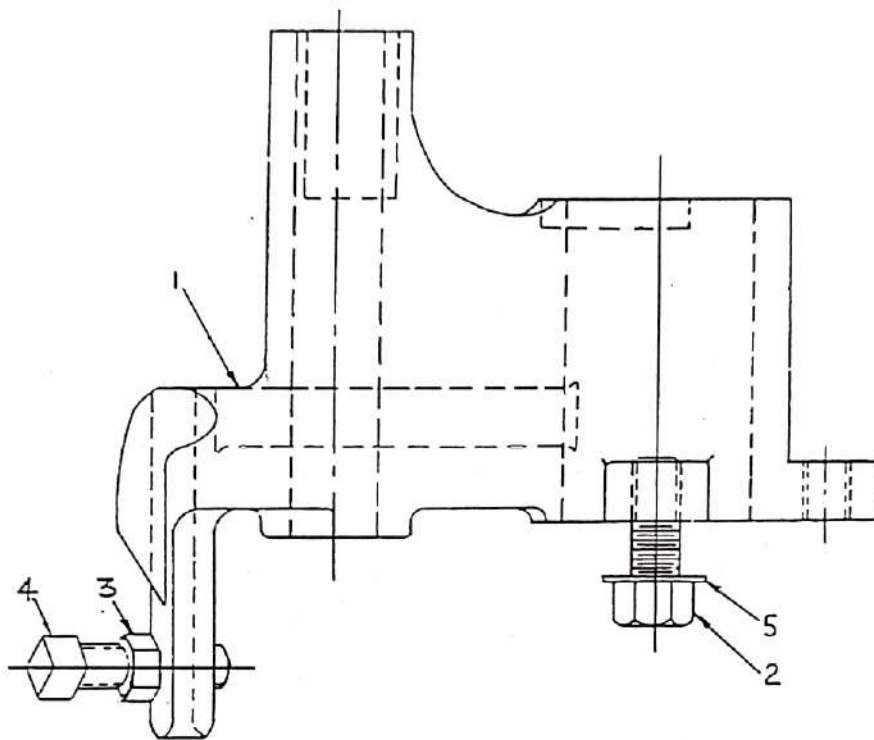

| Item No. | Part No. | Description | No. Off |
|----------|-------------|-------------|---------|
| 1 | 302104-0138 | Bracket | 1 |
| 2 | 865005-2734 | Cap Screw | 1 |
| 3 | 863006-2700 | Check Nut | 1 |
| 4 | 866008-2734 | Set Screw | 1 |
| 5 | 869016-2700 | Lockwasher | 1 |



Soot blower -IK300

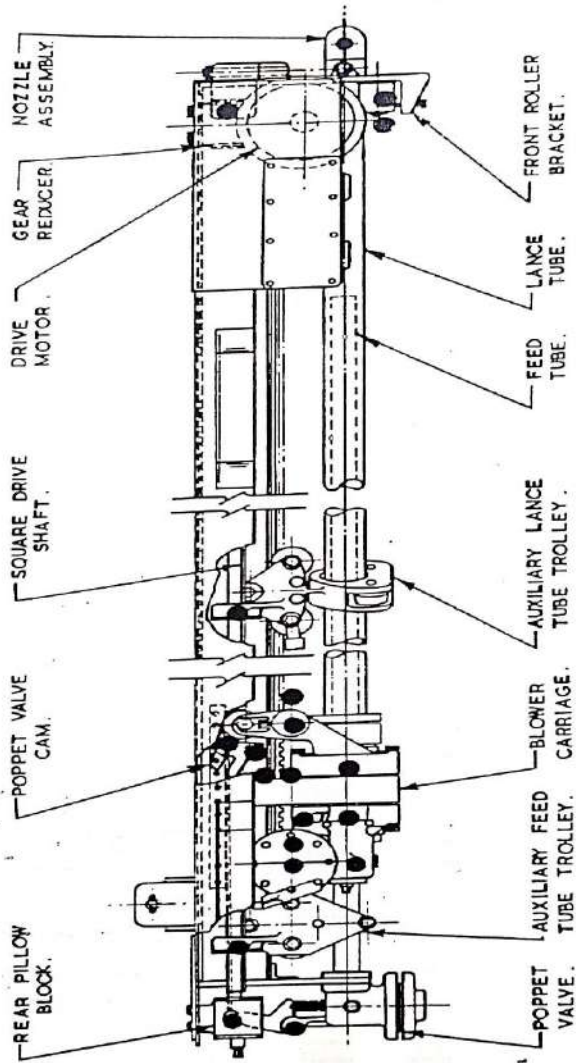

RETRACTABLE BLOWER .

● - MINI - LUBE - 17 LUBRICATION POINTS .



SECTION IV - PARTS IDENTIFICATION

REFER FIGURE-1

The correct part number for spares ordering can be identified by referring to the Parts List included in this manual. Please quote the correct number and the sootblower serial number when ordering spares.

| Item no. | Description | PartNo./Drg.No. | No.Off |
|---------------|---|--------------------------------|--------|
| 1 | Valve Body 600 series carbon steel(40Bar) | 393338-1141 B.AVB/SW/K3-518 | 1 |
| 1 | Valve Body 900 series carbon steel(60Bar) | 393337-1142 | 1 |
| | Valve Body 900 series Chrome Moly(60Bar) | | |
| | Valve Body 1800 series carbon steel(120Bar) | 393763-1145 | 1 |
| | Valve Body 1800 series Chrome Moly(120Bar) | | |
| 2 | Companion Flange | REFER L.O.M. | 1 |
| 3 | Companion Flange Gasket - 600 Series | | 1 |
| | Companion Flange Gasket - 900 Series | | 1 |
| | Companion Flange Gasket - 1800 Series | | 1 |
| 3A | Stud | | |
| 3B | Nut | | |
| 3C | Stud | | |
| 3D | Nut | | |
| 4 | Feed Tube Gasket | 304634-0117 | 1 |
| 5 | Pressure Control disc 600 & 900 | 394197-1123 | 1 |
| 5A | Pressure Control disc 1800 | 394199-1121/ 319599-1124 | 1 |
| 6 | Valve Stem & Disc Assy 600 | 309964-1023 | 1 |
| 6A | Valve Stem & Disc Assy 900 | 309964-2021 | 1 |
| 6B | Valve Stem & Disc Assy 1800 | 319917-1020 | 1 |
| 7 | Flexible Valve seat 600 | 309786-1128 | 1 |
| 7A | Flexible Valve seat 900 | 310666-2129 | 1 |
| 7B | Flexible Valve seat 1800 | 319916-21128 | 1 |
| 8 | Valve Steam Guide | 302031-0110 | 1 |
| 9 | Lock pin Plug 600 & 900 | 393802-1122 | 1 |
| 9A | Lock pin Plug 1800 | 393803-1121 | 1 |
| 10 | Air relief valve assy | | 1 |
| 11 | Valve Guide washer | 301167-0118 | 1 |
| 12 | Valve Stem packing (set) | 302034-0117 | 1 |
| 13 | Packing Nut | 302032-0119 | 1 |
| 14 | Packing Washer | 302027-0116 | 1 |
| 15 | Valve Spring | 302051-0115 | 1 |
| 16 | Valve spring retainer | 301808-0113 | 1 |
| 17 | Valve Yoke | 301142-0118 | 1 |
| 17A | Valve Yoke Pin | 309187-0117 | 1 |
| 17B | Cotter Pin 3/32"x 1 1/4" lg. | 863607-1716 | 1 |
| 18 | Grease Nipple | 906902-0003 | 1 |
| 19 | Trigger Pin 1/8"x 1 1/4" | 301158-0119 | 1 |
| 20 | Cotter Pin 1/8"x 1 1/4" | 863603-1934 | 1 |
| 21 | Trigger | 309183-0129 | 1 |
| 22 | Pillow Block Shaft | 305576-0122 | 1 |
| 23 | Name Plate | 306275-0116 | 1 |
| 24 | Shoulder Bolt | 309428-0116 | 1 |
| 25 | Bearing | 901118-0049 | 1 |
| 25A | Hex Nut 3/4 in.- 10 | 863015-3200 | 1 |
| 25B | Lockwasher 3/4 in. | 869016-3200 | 1 |
| 25C | Washer 3/4 in. | 305666-0115 | 1 |
| 25D | Grease Nipple | 906902-0010 | 1 |
| 26 | Pillow Block | 305574-0124 | 1 |
| 26A | Plug 1/8 in. I.P.S. | 936220-8200 | 1 |
| 27 | Ball Bearing | 901110-0016 | 2 |
| 28 | Seal Flange | 305575-0115 | 2 |
| 28A | Shim 1/16 in. | 305579-0111 | 2 |
| 28B | Shim 1/8 in. | 305580-0118 | 3 |
| 28C | Hex Hd. Cap screw 3/8 - 16x1 in. | 865005-2732 | 8 |
| 28D | Lockwasher 3/8 in. | 869016-2700 | 8 |
| 29 | Oil Seal | 904532-0008 | 2 |
| 30 | Poppet valve Block | 305670-1117 | 1 |
| 30A | Hex Jam Nut 5/8 in. -18 | 863007-6000 | 2 |
| 31 | Spacer | 305582-0116 | 1 |
| 32 | Plate | 305581-0117 | 1 |
| 32A | Thumb Screw 3/8- 16 x 1 in. | 867210-2732 | 1 |
| 32B | Lockwasher 3/8 in. | 869011-2700 | 1 |
| 33 | Bearing | 309169-0119 | 1 |



| Item no. | Description | PartNo./Drg.No. | No.Off |
|----------|--|-----------------------------|--------|
| 33A | Hex Hd. Cap screw 1/4 - 20x3/4 in. | 865005-2524 | 4 |
| 33B | Lockwasher 1/4 in. | 869016-2500 | 4 |
| 34 | Grease Fitting | 906902-0004 | 1 |
| 35 | Poppet Arm 32 in. | 309423-1119 | 1 |
| 36 | Cam assy.R.H. | 309427-1024 | 1 |
| 36/1 | CAM | 309429-0123 | 1 |
| 36/2 | PIN | 309430-0112 | 1 |
| 36A | Retaining Ring | 907920-0008 | 1 |
| 36B | Cam assy.L.H. | 309432-1027 | 1 |
| 36C | Retaining Ring | 907920-0008 | 1 |
| 37 | Grease Nipple | 906902-0006 | 1 |
| 38 | Grease Cup | 903305-0005 | 1 |
| 39 | Grease Nipple | 906902-0010 | 1 |
| 40 | Socket Hd. Cap Screw 1/4 - 28 x 5 3/8 in. | 309388-0114 | 4 |
| 40A | Locknut 1/4 in. - 28 | 863013-5400 | 4 |
| 40B | Hex Nut 1/4 in. - 28 | 863015-5400 | 4 |
| 41 | Connecting Link 5/8 in.(For Item no.42) | 902119-0012 | 1 |
| 42 | Chain 5/8 in.x 60.26 1/4 in. c/w connecting link | 902120-0004 | 1 |
| 42A | Cranked Link 5/8 in.x 50 | 902119-0013 | 1 |
| 43 | Double Drive Sprocket | 311650-1023 | 1 |
| 44 | Chain 1/2 in.x 40 : 44 in. | 902119-0002 | 1 |
| 45 | Connecting Link 1/2 x 40 | 308941-0116 | 1 |
| 46 | Spacer | 90110-0039 | 2 |
| 47 | Ball Bearing | 308942-0115 | 1 |
| 48 | Bearing Spacer | 309454-0113 | 1 |
| 49 | Spacer Ring | 309450-0111 | 2 |
| 50 | Pin | 310050-1125 | 1 |
| 51 | Bracket | 312241-1121 | 1 |
| 52 | Drive Nut | | |
| 54 | Spacer | 309368-0110 | 3 |
| 55 | Square Shaft Cleaner | 309321-0114 | 1 |
| 56 | Grease Nipple | 906902-0017 | 1 |
| 57 | Grease Cup | 903305-0005 | 1 |
| 58 | Idler Eccentric | 305348-1127 | 1 |
| 58A | Socket Hd. Cap Screw 3/8 - 16 x 3/4 in. | 866006-2724 | 1 |
| 58B | Socket Hd. Cap Screw 3/8 - 16 x 1/2 in. | 866006-2712 | 1 |
| 59 | Roller Bracket Latch | 308646-1112 | 2 |
| 59A | Roll Pin 3/16 dia x 2 in. | 863651-2240 | 2 |
| 60 | Square Shaft | | 1 |
| 61 | Bearing Retainer Plate | 305545-0112 | 1 |
| 62 | Bearing | 309169-0119 | 1 |
| 62A | Hex. Hd. Cap Screw 1/4 - 20 x 3/4 in. | 865005-2524 | 4 |
| 62B | Lockwasher 1/4 in. | 869016-2500 | 4 |
| 63 | Actuating Lever | SKT/MISC/Q-2414 | 2 |
| 63A | Locknut 1/4 in. | 863013-2500 | 2 |
| 64 | Limit Switch | 847310-0010 | 2 |
| 65 | Cable Gland (F.L.S.) | 849518-8907 | 1 |
| 66 | Cable | 848518-8903 | |
| 67 | Cable | 848518-8903 | |
| 68 | Cable Gland | 849518-8907 | 1 |
| 69 | Conduit Reducer 3/4 x 1/2 in. | 849911-0008 | 1 |
| 70 | Cable | 849518-8903 | |
| 70A | Cable Gland Limit Switch | 849518-8911 | 1 |
| 71 | Cable Gland | 849518-8915 | 1 |
| 72 | Cable Gland | 849518-8915 | 2 |
| 73 | Cable | 849518-8903 | |
| 74 | Output Shaft | 308907-0126/ 308907-1132 | 1 |
| 75 | Reinforcement Hub Assy. | 305214-1029 | 4 |
| 75A | Hub | 305213-0113 | 1 |
| 75B | Hex.Hd.Bolt 5/16 - 18 x 1 1/4 in. | 865063-2634 | 4 |
| 75C | Lockwasher 5/16 in. | 869016-2600 | 4 |
| 76 | Oil Seal | 907806-0039 | 4 |
| 77 | Open Cover | 305030-1138 | 4 |
| 78 | Output Bearing | 907806-0033 | 1 |
| 78A | Oil level Tag | 907806-0044 | 2 |
| 79 | Shim | 305135-0111 | |
| 80 | Blind Cover | 305031-1137 | 1 |
| 81 | Front Roller Bracket Assy.(Up to 24' Travel) | 309596-1037 | 1 |
| 81A | Support Assembly | 309787-1036 | 1 |

Allen Bolt
16xM6
Ground
Torque



| Item no. | Description | PartNo./Drg No. | No. Off |
|----------|---|-----------------------------------|---------|
| 81B | Front Roller Bracket Assy (Over 24' Travel) | 308399-2030 | 1 |
| 81C | Support Assembly | 309391-1026 | 1 |
| 82 | Wallbox Support Assembly | 309392-1025 | 1 |
| 82A | Hex Nut 1 1/4 in. - 7 | 863015-3600 | 1 |
| 82B | Roll Pin 3/16 dia x 1 3/4 in. | 863651-2238 | 1 |
| 83 | Nameplate | 907806-0034 | 1 |
| 84 | Shoulder Screw | 305319-0116 | 2 |
| 85 | Negative Pressure Wall Box Assembly | 309439-1038 | 1 |
| 86 | Bushing | 305636-0112 | 1 |
| 86A | Socket Head Cap Screw 3/8 - 16 x 3/4 in | 865007-2724 | 6 |
| 86B | Gasket | 310684-1111 | 1 |
| 86C | Lockwasher 3/8 in. | 869016-2700 | 6 |
| 87 | Square Head Pipe 1/4 in. | 936318-8300 | 1 |
| 88 | Flat Washer 1 in. | 869006-3400 | 2 |
| 89 | Cotter Pin | 308431-0112 | 2 |
| 90 | Adjusting Screw | 305316-0119 | 2 |
| 90A | Hex Jam Nut 3/4 in. - 10 | 863006-3200 | 2 |
| 91 | Terminal Block (12 Pole) | 393095-6044 | 1 |
| 91A | Rd. Hd. Screw 1/4 - 20 x 3/8 in. | 865608-2512 | 3 |
| 93 | Terminal Box Rear Motor L.H. | 393093-1047 | 1 |
| 93A | Terminal Box Front Motor R.H. | 393093-1047 | 1 |
| 93B | Terminal Box Front Motor R.H. | 304648-1143 | 1 |
| 93C | Terminal Box Front Motor L.H. | 304648-1143 | 1 |
| 94 | Push Button - Start | 847360-9000 | 1 |
| 94A | Push Button - Green Insert | 847360-9003 | 1 |
| 94B | Push Button - Reverse | 847360-9000 | 1 |
| 94C | Push Button - Red Insert | 847360-9001 | 1 |
| 95 | Push Button Switch - Standard (Contact Block) | 847360-9004 | 1 |
| 95A | Push Button - Heavy Duty (Contact block) | 847360-9004 | 1 |
| 96 | Feed Tube Assy | | 1 |
| 97 | Lance Tube Assembly | | 1 |
| 98 | Stud | 305550-0114 | 2 |
| 98A | Hex. Nut 1/2 in.- 13 | 863015-2900 | 5 |
| 98B | Lockwasher 1/2 in. | 869016-2900 | 9 |
| 99 | Roller Pin | 309418-0118 | 2 |
| 100 | Collar | 309381-0111 | 2 |
| 101 | Roller Assembly (3 1/2 in. Lance) | 309436-1023 | 2 |
| 102 | Roller Bracket | 305564-0126 | 1 |
| 102A | Socket hd. Set Screw 3/8 - 16 x 3/4 in. | 866005-2724 | 2 |
| 102B | Hex. Hd. Cap Screw 1/2 - 13 x 1 1/2 in. | 865005-2936 | 4 |
| 103 | Flange | 305657-0116 | 1 |
| 103A | Hex. Hd. Cap Screw 1/2 - 13 x 1 3/4 in. | 333771-1125 | 6 |
| 104 | Gasket Lance Tube | 305656-0117 | 1 |
| 105 | Hub Flange | 305654-0127 | 1 |
| 106 | Key | 304160-0119 | 1 |
| 107 | Idler Sprocket 10 Teeth - 5/8 in. Pitch | EAVB/SW/IK3-513 | 1 |
| 108 | Roller Bearing JL 1212 | 901114-0002 | 1 |
| 109 | Pipe Plug Plastic 1/8 in. | 936371-3200 | 1 |
| 110 | Retaining Ring | 907920-0007 | 1 |
| 111 | Washer | 305347-0112 | 2 |
| 112 | Sprocket 9 teeth | EAVB/SW/IK3-514 | 1 |
| 112A | Roll Pin 1/4" x 1 1/2" | 863651-2535 | 1 |
| 112B | Roll Pin 5/32" x 1 1/2" | 863651-2135 | 1 |
| 112C | Woodruff Key | 862402-0006 | 1 |
| 113 | Chain Guard 4 x 18 1/2 in. | 305323-0128 | 1 |
| 113A | Round Hd. self tapping Screw 10-32 x 5/16 in. | 866526-5010 | 5 |
| 114 | Oil Seal | 904532-0001 | 2 |
| 115 | Idler Flange | 305361-0121 | 1 |
| 115A | Hex Head Cap Screw 3/8 - 16 x 1 1/8 in. | 865005-2733 | 8 |
| 115B | Lockwasher 3/8 in. | 869016-2700 | 8 |
| 116 | Ball Bearing | 901110-0005 | 3 |
| 117 | Sleeve Spacer (Travel cover 24 ft.) | 309376-0118 | 1 |
| 118 | Worm (Travels up to 24 ft.) | 305350-0117 | 1 |
| 119 | Worm Key (Travels up to 24 ft.) | 305333-0118 | 1 |
| 120 | Gasket | 305357-0119 | 2 |
| 121 | Flange | 305356-0110 | 1 |
| 122 | Operating Shaft (Travels up to 24 ft.) | 311652-1125 | 1 |
| 122A | Integral Worm Shaft (Travels over 24 ft.) | 312935-1122/ C. SKT/MISC/H-930 | 1 |
| 123 | Limit Switch Trip R.H. Shown | 393620-1120 | 1 |



| Item no. | Description | Part No./Org.No. | No. Off |
|----------|---|-------------------|---------|
| 123A | Limit Switch Trip L.H. Shown | 303021-1120 | 1 |
| 123B | Square Hd. Bolt 3/8 - 10 x 1in. | 001011-2732 | 1 |
| 124 | Feed Tube Key | 301017-0114 | 1 |
| 125 | Stud | 305500-0110 | 4 |
| 125A | Hex Nut 3/4 in. | 101237-0115 | 4 |
| 126 | Feed Tube Flange | 300505-0111 | 1 |
| 127 | Pinion | 305320-0114 | 1 |
| 128 | Pinion Key | 305333-0118 | 2 |
| 129 | Shaft | 300377-0125 | 1 |
| 130 | Collar | 300320-0110 | 1 |
| 130A | Cotter Pin 3/16x2 1/2 in. | 003007-2242 | 1 |
| 131 | Inner Race | 001114-0005 | 3 |
| 132 | Stud | 305325-0118 | 2 |
| 132A | Hex Nut 3/4 in. | 003015-3200 | 8 |
| 132B | Lockwasher 3/4 in. | 000016-3200 | 8 |
| 133 | Outer Race | 001114-0004 | 3 |
| 134 | Rear Trolley Bracket | 300017-0139 | 1 |
| 135 | Grease Fitting | 000902-0004 | 2 |
| 136 | Bushing | 300335-0118 | 1 |
| 136A | Groove Pin 1/4" x 2 1/2" | 003031-2542 | 1 |
| 137 | Shaft | 300377-0125 | 1 |
| 138 | Collar | 300322-0113 | 1 |
| 139 | Grease Nipple | 000902-0011 | 4 |
| 140 | Cotter Pin 1/8 x 2 3/4 in. | 300481-0112 | 2 |
| 141 | Shoulder Shaft R.H. | E AVB/SW/IK3-501 | 1 |
| 142 | Ball Bearing | 001110-0023 | 2 |
| 143 | Trip Pin Support Assembly R.H. | 305394-1021 | 1 |
| 143A | Trip Pin Support Assembly L.H. | 305389-1028 | 1 |
| 144 | Trip Stud | 305674-0115 | 1 |
| 145 | Flat Lockwasher | 305390-0118 | 1 |
| 145A | Socket hd. Cap Screw 1/2 - 13 x 1 1/4 in. | 005007-2834 | 1 |
| 145B | Lockwasher 1/2 in. | 000016-2800 | 1 |
| 146 | Spacer | 300420-0110 | 1 |
| 147 | Plain Washer 7/8 in. Dia. | 000008-3300 | 2 |
| 148 | Support Pin 7/8 x 9 1/8 in. | 300421-0119 | 1 |
| 148A | Cotter Pin 3/16 x 1 1/2 in. | 003007-2238 | 2 |
| 149 | Ball Bearing | 001110-0026 | 2 |
| 150 | Worm Gear Housing | 003780-1140 | 1 |
| 151 | Gasket | 300375-0119 | 1 |
| 152 | Gear case Cover | 300372-0120 | 1 |
| 152A | Hex. Hd. Cap Screw 1/4 - 20 x 3/4 in. | 000005-2524 | 8 |
| 152B | Lockwasher 1/4 in. | 000016-2500 | 8 |
| 153 | Pinion Key | 305333-0118 | 2 |
| 154 | Thrust Washer | 305330-0111 | 1 |
| 155 | Oil Sight Window | 004715-0006 | 1 |
| 156 | Thrust Washer | 300371-0113 | 1 |
| 156A | Pipe Plug Plastic 1/2 in. | 003648-3500 | 1 |
| 157 | Worm Wheel | 305331-0110 | 1 |
| 158 | Oil Sight Window | E.SKT/MISC/Q-1337 | 1 |
| 159 | Bushing | 300336-0117 | 1 |
| 159A | Groove Pin 1/4" x 2 1/2" | 003031-2542 | 1 |
| 160 | Sleeve | 300426-0118 | 1 |
| 161 | Flanged Roller | 300334-0119 | 2 |
| 162 | Collar | 300324-0111 | 1 |
| 163 | Chain Guard (3/4 x 12 1/2 in.) | 305322-0111 | 1 |
| 164 | Stud | 305335-0116 | 2 |
| 165 | Latch | 300046-1112 | 2 |
| 165A | Roll Pin 3/16 x 2 in. | 003051-2240 | 2 |
| 166 | Side Plate With Bearing Housing | 305554-0128 | 1 |
| 167 | Flanged Roller Assembly | 310504-1025 | 4 |
| 168 | Trip Bar | 300374-0119 | 1 |
| 168A | Set Screw Cup Pt. 1/4 - 20 x 1/4 in. | 000002-2508 | 1 |
| 169 | Roller Spacer | 307058-0110 | 1 |
| 170 | Side Plate | 305540-0128 | 1 |
| 171 | Latch Rod - L.H. | 300377-0116 | 1 |
| 171A | Latch Rod - R.H. | 300375-0118 | 1 |
| 172 | Spacer | 305552-0112 | 2 |
| 173 | Spacer washer | 305300-0118 | 2 |
| 174 | Stud | 305555-0119 | 1 |
| 174A | Hex Nut 1/2 in.-13 in. | 003015-2900 | 9 |



| Item no. | Description | PartNo./Drg.No. | No.Off |
|----------|--|----------------------------|--------|
| 174B | Lockwasher 1/2 in. | 860016-2900 | 9 |
| 175 | Shoulder Shaft | 309171-0115 | 2 |
| 176 | Cotter Pin 1/8 x 2 3/4 in. | 308481-0112 | 2 |
| 177 | Bearing Retainer Plate | 305545-0112 | 1 |
| 178 | Spacer washer | 309347-0114 | 2 |
| 179 | Roller Assembly | 309172-1021 | 1 |
| 180 | Latch Pin Assembly | 300359-1026 | 1 |
| 180A | Hex.Jam Nut 1/2 in.-13 | 863008-2900 | 1 |
| 181 | Shaft Blowers without Aux.Trolleys or with Rear Aux.Trolley Only | 309357-0129 | 1 |
| 181A | Shaft Blowers with Aux.Trolleys | 309358-0128 | 1 |
| 182 | Cotter Pin 1/8 x 2 3/4 in. | 308481-0112 | 4 |
| 183 | Woodruff Key 3/16 x 3/4 in. | 862402-0004 | 1 |
| 184 | Grease Fitting 1/8 in. | 906902-0011 | 1 |
| 186 | Bushing | 309359-0119 | 1 |
| 186A | Groove Pin 1/4 x 2 1/2 in. | 863631-2542 | 1 |
| 187 | Shoulder Shaft | E AVB/SW/IK3-502 | 1 |
| 188 | Front Trolley Bracket | 306618-0138 | 1 |
| 189 | Ball Bearing | 901110-0023 | 2 |
| 190 | Carriage Roller | 309337-0116 | 4 |
| 191 | Spacer washer | 305366-0118 | 4 |
| 192 | Outer Bearing | 901114-0004 | 2 |
| 193 | Inner Bearing | 901114-0005 | 2 |
| 194 | Flanged Roller | 309334-0119 | 4 |
| 195 | Shoulder Shaft | E AVB/SW/IK3-501 | 1 |
| 196 | Bushing | 305367-0117 | 1 |
| 196A | Groove Pin 1/4 x 2 1/2 in. | 863631-2542 | 1 |
| 197 | Packing 3/8 x 1 7/8 in. | 907605-0008 | 2 |
| 198 | Ball Bearing | 901110-0118 | 2 |
| 199 | Retaining Ring | 907920-0006 | 2 |
| 200 | Key | 305342-0117 | 1 |
| 201 | Sprocket - 48 Teeth | 305341-0118 | 1 |
| 202 | Packing Bushing | 305340-0119 | 1 |
| 203 | Lance Hub | 390846-1134 390846-1035 | 1 |
| 204 | Packing (Graphite Fibre) | 346162-1132 346160-1134 | 1 |
| 204A | Teflon Packing - Continuous Ring | 346160-1134 | 1 |
| 204B | Teflon Packing - Split Ring | 346162-1132 | 1 |
| 205 | Packing Gland | 310026-1126 | 1 |
| 205A | Stud 1/2 - 13 x 4 in. | 300951-1126 | 2 |
| 205B | Hex Nut 1/2 in. - 13 | 863015-2900 | 2 |
| 205C | Hex Lock Nut 1/2 in.-13 | 863008-2900 | 2 |
| 205D | Plain Washer 1/2 in. | 869006-2900 | 2 |
| 205E | Knurled Spacer - Teflon Packing only | 392350-1120 | 2 |
| 206 | Grease Fitting | 906902-0111 | 1 |
| 207 | Side Plate | 305563-0127 | 1 |
| 208 | Spacer | 305561-0111 | 2 |
| 209 | Latch Rod-Auxiliary Lance Support | 300376-0117 | 1 |
| 210 | Trip Bar | E.AVB/SW/IK3-517 | 1 |
| 210A | Allen Screw 1/4 - 20 x 1/4 in. | 866002-2508 | 1 |
| 211 | Flanged Roller Assembly | 316504-1025 | 4 |
| 211A | Hex. Hd. Bolt | 305550-0114 | 2 |
| 212 | Shoulder Shaft | 309171-0115 | 2 |
| 213 | Side Plate | 305562-0128 | 1 |
| 214 | Cotter Pin 1/8 x 2 3/4 in. | 308481-0112 | 2 |
| 215 | Spacer Washer | 305366-0118 | 2 |
| 216 | Roller assembly | | 2 |
| 217 | Spacer washer | 309347-0114 | 2 |
| 218 | Key | 300441-0118 | 1 |
| 219 | Primary Helical Pinion | 392725-1128 | 1 |
| 220 | Primary Bearing | 901110-8904 | 1 |
| 221 | Oil Plug (For Item No.219) | 305034-0110 | 1 |
| 222 | Primary Bearing | 907606-0035 | 1 |
| 223 | Reducer Housing (Sub Assy.) | 392719-1043 | 1 |
| 224 | Worm 100 in./Min. 40:1 | 305157-0129 | 1 |

Front
drive
axle



| Item no. | Description | PartNo /Drg No. | No.Off |
|----------|---|-----------------------------|--------|
| 224A | Worm 70 and 35/Min. 60:1 | 305158-0128 | 1 |
| 224B | Worm 70/Min. 20:1 | 314190-1128 | 1 |
| 224C | Worm 30:1 Ratio | 310094-1127 | 1 |
| 225 | Roller Bracket Assy. R.H. 3 1/2 in. Lance | 300484-1036 | 1 |
| 226 | Roller Bracket Assy. L.H. 3 1/2 in. Lance | 300484-3038 | 1 |
| 227 | Secondary Bearing Retainer | 305332-0112 | 1 |
| 228 | Socket Pipe Plug 3/4 in. | 030418-8600 | 1 |
| 229 | Oil Filler Plug 3/8 in. | 305156-0112 | 1 |
| 230 | Worm Wheel 100 in./ Min. 40:1 | 305159-0127 | 1 |
| 230A | Worm Wheel 70 and 35 in./Min. 60:1 | 305160-0124 | 1 |
| 230B | Worm Wheel 70 in./Min.20:1 | 314191-1127 | 1 |
| 230C | Worm Wheel 30:1 Ratio | 318995-1126 | 1 |
| 230D | Key 3/8 x 3/8 x 2 1/2 in. | 907806-0041 | 1 |
| 231 | Primary Helical Gear <i>38 teeth</i> | 305153-0115 | 1 |
| 232 | Key 1/4 x 1/4 x 1 in. | 305153-1121 | 1 |
| 233 | Oil Level Gauge | 907806-0040 | 1 |
| 234 | Roller Bearing | 904715-0005 | 1 |
| 235 | Oil Seal | 907806-0037 | 2 |
| 236 | Motor Mounting Flange | 904565-8901 | 1 |
| 237 | | 392723-1138 | 1 |
| 238 | Electric Motor | - | 1 |
| 239 | Gasket | 393097-1134 | 1 |
| 240 | Cover | 307867-0126 | 1 |
| 240A | Round Hd. Set Screw 1/4-20x3/4 in. | 393096-1135 | 8 |
| 240B | Lockwasher 1/4 in. | 875652-3520 | 16 |
| 241 | Plus Pressure Wallbox assembly 2 in. conns.+ Item 242 | 310097-3035 | 1 |
| 241A | Plus Pressure Wallbox assembly 1 1/2 in. conns.+ Item 242 | 310097-1039 | 1 |
| 242 | Aspirating Ring | | 1 |
| 243 | Nozzle Assembly | | 1 |
| 244 | Air seal Ring 3 1/2 in.Lance | 305594-0120 | 1 |
| 244A | Gasket | 310684-1111 | 1 |
| 244B | Socket Head Cap Screw 3/8 - 16 x 3/4 in. | 865007-2724 | 6 |
| 244C | Lockwasher 3/8 in. | 869016-2700 | 12 |
| 245 | Roller Bracket | 305648-0126 | 1 |
| 246 | Lance Roller | 305564-0126 | 2 |
| 247 | Roller Pin | 309842-1120 | 2 |
| 248 | Collar | DAVB/SW/IK3-503 | 2 |
| 249 | Ball Bearing | 309754-1126 | 2 |
| 250 | Bearing Spacer | EAVB/SW/IK3-504 | 2 |
| 251 | Nylon Bearing Seal | 309753-1119 | 2 |
| 252 | Retaining Ring | EAVB/SW/IK3-505 | 4 |
| 253 | Self locking Nut 1/2 in. | 901110-0028/ 901110-0025 | 2 |
| 254 | Socket Grub screw 3/8 x 1/2 in.Long | 309843-1111 | 4 |
| 255 | Socket Grub screw 3/8 x 3/8 in.Long | 309474-0119 | 4 |
| 256 | Elbow 45 | 907920-0024 | 2 |
| 257 | Grease Cup | 863024-5800 | 2 |
| 258 | Idler Sprocket 13 Teeth | 866007-2716 | 2 |
| 259 | Bearing | 866005-2712 | 2 |
| | | 906902-0021 | 2 |
| | | 903305-0005 | 2 |
| | | E.AVB/SW/IK3-515 | 1 |
| | | 901114-0002 | 1 |



POPPET VALVE ASSEMBLY (60 BAR)

DRG. NO. 393805-1032
PART NO. 393805-1032 (C.S.)

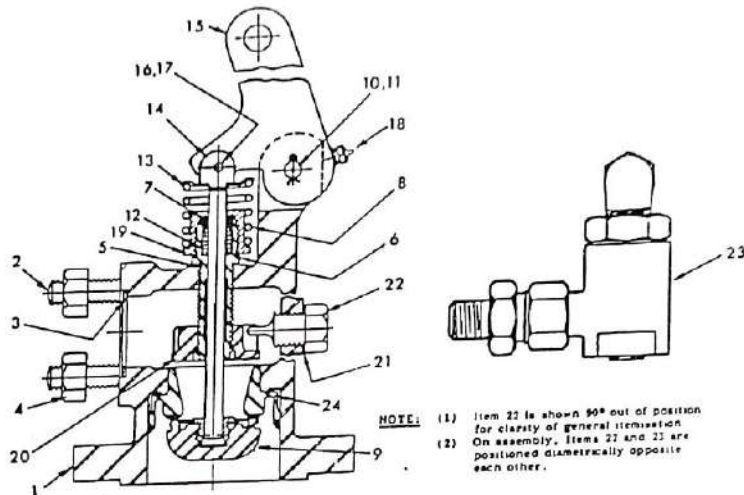

| Item No. | Part No. | Description | No. | Off |
|----------|-------------|---------------------------|-----|-----|
| 1 | 393337-1142 | Valve Body (Cast Steel) | 1 | |
| 2 | 305590-0116 | Stud | 4 | |
| 3 | 304634-0117 | Gasket | 1 | |
| 4 | 101237-6115 | Nut | 4 | |
| 5 | 301167-0118 | Valve Guide Washer | 1 | |
| 6 | 302031-0110 | Valve Stem Guide | 1 | |
| 7 | 302027-0116 | Packing Washer | 1 | |
| 8 | 302051-0115 | Valve Spring | 1 | |
| 9 | 309964-2021 | Valve Stem and Disc | 1 | |
| 10 | 301158-0119 | Trigger Pin | 1 | |
| 11 | 863603-1934 | Cotter Pin | 1 | |
| 12 | 302034-0117 | Valve Stem Packing | 1 | |
| 13 | 301808-0113 | Valve Spring Retainer | 1 | |
| 14 | 301142-0118 | Valve Yoke | 1 | |
| 15 | 309183-0129 | Trigger | 1 | |
| 16 | 301235-0116 | Valve Yoke Pin | 1 | |
| 17 | 863603-1716 | Cotter Pin | 1 | |
| 18 | 906902-0003 | Lubrication Fitting | 1 | |
| 19 | 302032-0119 | Packing Nut | 1 | |
| 20 | 394197-1123 | Pressure Control Disc | 1 | |
| 21 | 930711-9034 | Lock Pin Washer | 1 | |
| 22 | 393802-1122 | Lock Pin | 1 | |
| 23 | 394314- | Air Relief Valve Assembly | 1 | |
| ** 24 | 310666-1121 | Flexible Valve Seat | 1 | |

** Oversize valve seat, Part Number 310666-2129, supplied for service replacement.

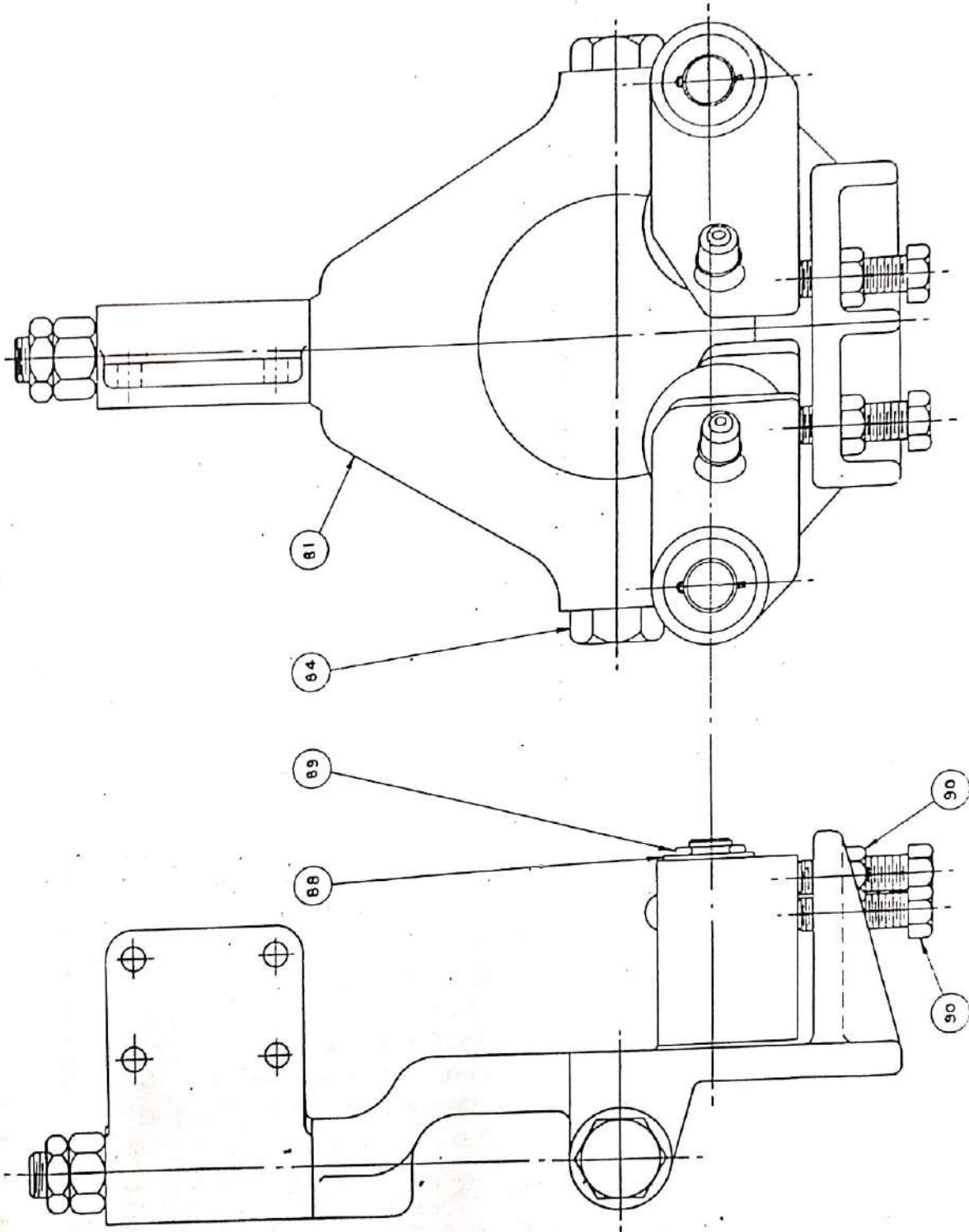

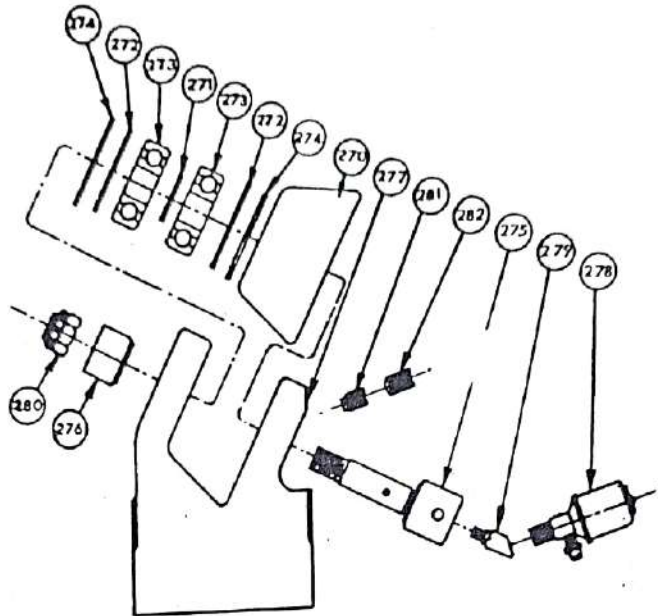

| ITEM N° | DESCRIPTION | REQ'D |
|---------|---|-------|
| 270 | ROLLER; 3 1/2 LANCE . | 1 |
| 270 | ROLLER; 3 3/4 LANCE } | 1 |
| 271 | RETAINING RING, NATIONAL . | 2 |
| 272 | SEAL . | 2 |
| 273 | BEARING, M.R.C. 303-S.F. | 2 |
| 274 | RETAINING RING, TRUARC. | 2 |
| 275 | PIN. | 1 |
| 276 | COLLAR . | 1 |
| 277 | ROLLER BRACKET . | 1 |
| 278 | GREASE FITTING, ALEMITE . | 1 |
| 279 | ELBOW, ALEMITE . | 1 |
| 280 | 1/2 STOP NUT. E.S.N.A. TYPE . | 1 |
| 281 | 3/8 - 16 x 3/8 SOCKET HEAD HALF DOG SET SCREW | 1 |
| 282 | 3/8 - 16 x 1/2 SOCKET HEAD OVAL POINT SET SCREW . | 1 |

ROLLER BRACKET ASSEMBLY.

APRIL, '66.

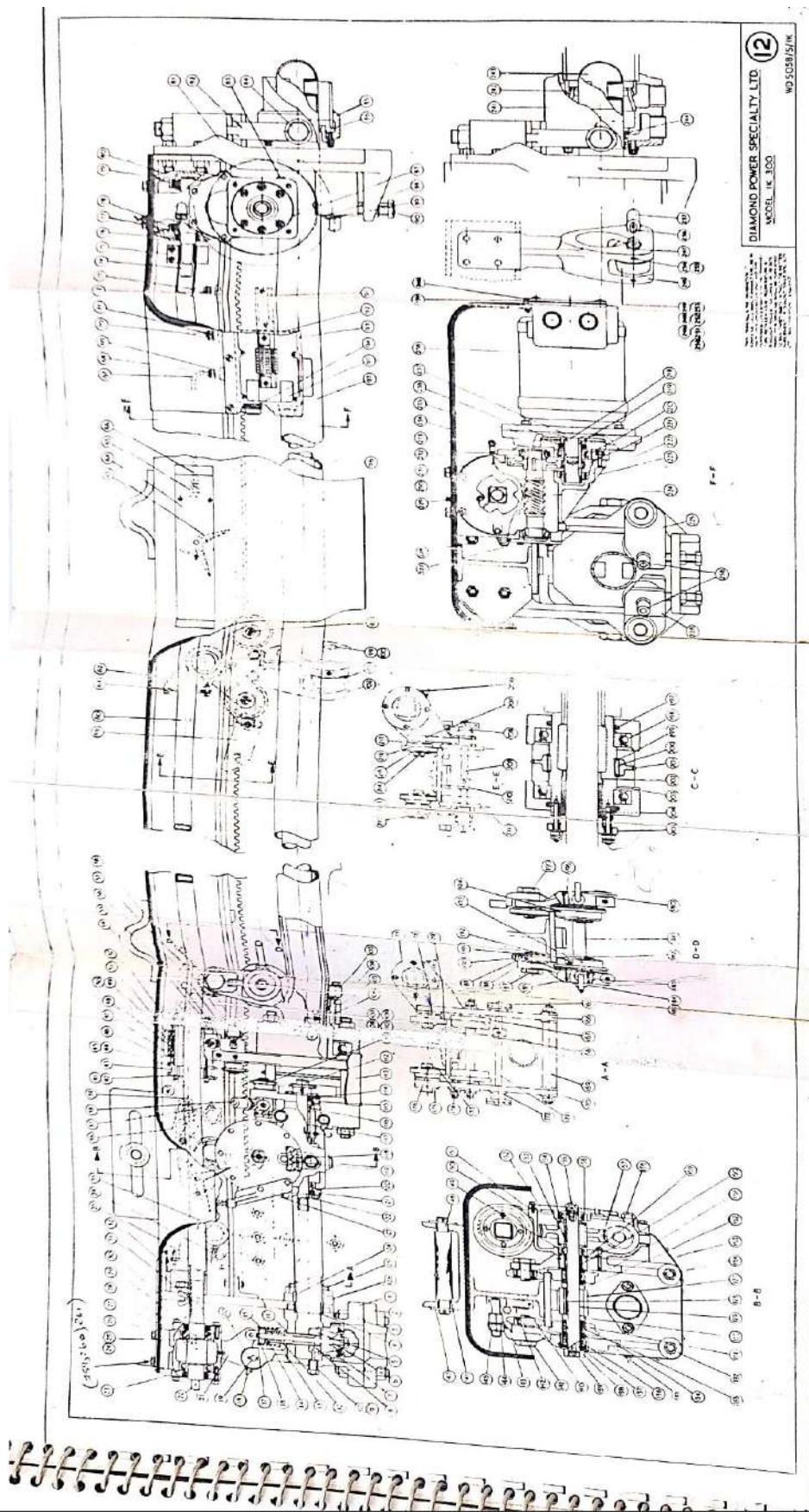

DIAMOND POWER SPECIALTY LTD.
MODEL: UK 100
WD 50381/51/K

12