



# **Gujarat Mineral Development Corporation Limited**

## **Tender Document For**

---

**The  
“Supply of Mechanical spares for Boiler ”  
at  
2 x125MW Akrimota Thermal Power Station**

**Tender Number GMDC/ATPS/BMD Spares-39 /21-22**

---

**General Manager (Power)  
Gujarat Mineral Development Corporation Ltd.  
(A Govt. Of Gujarat Enterprise)**

**CIN : L14100GJ1963SGC001206, GST : 24AAACG7987P1ZT**

**Khanij Bhavan, 132' Ring Road, University Ground, Vastrapur, Ahmedabad 380 052**

**☎EPABX :079-27913501, 27913200**

**E-mail : power@gmdcltd.com , jndave@gmdcltd.co.in, Website :www.gmdcltd.com**



## Table of Contents

CI No.	Particulars	Page No.
1.	Purpose of the Document	6
2.	About GMDC	7
3.	Location of Work	7
4.	About ATPS	7
5.	General Instruction to Bidder	7
5.1	Cost of bidding	8
5.2	Due Diligence	8
5.3	Clarification of Bidding Documents	8
5.4	Amendment of Tender Document	8
5.5	Contact Details	8
5.6	Language of Bid	9
5.7	Late Bids	9
5.8	Right to Accept Proposal	9
5.9	Site Visit	9
5.10	Period of Validity of Bids	10
5.11	Sub Contract	10
5.12	Consortium / Joint Venture	10
5.13	Change in Law	10
5.14	Interpretation	10
5.15	Acceptance of All The Terms and Condition	10
5.16	Declaration	10
6	Earnest Money Deposit	11
7	Tender Processing Fee	11
8	Security Deposit	12
9	Procedure for Submission of the Bid	13
10	Eligibility and Qualification Criteria of Bidder	14
10.1	Experience	14
10.2	Financial	15
10.3	Site Visit Certificate	15



10.4	Blacklisting of the Bidder	15
11	Scope of Work	16
12	Measurement	21
13	Liquidated Damages (LD)	21
14	Performance Guarantee	21
15	Goods & Service Tax	21
16	Insurance	22
17	Payment Terms	23
18	Evaluation of Bids	23
18.1	Completeness of Bids	23
18.2	Tender Clarification	24
18.3	Rejection of Bids	24
18.4	Opening of Bids	24
18.5	Selection of Bidder	24
18.6	Negotiation	24
18.4	Acceptance of LOI and Award of Contract (Work order)	25
19	Statutory Obligations	25
20	Bankruptcy	27
21	Notice	27
22	Canvassing Not Permitted	28
23	Termination of Supply	28
24	Arbitration	28
25	Governing Law	28
26	Jurisdiction	28
27	Non Fulfillment of Terms And Condition of The Contract	29
28	Completion Of Supply	29
29	Accident and Responsibilities of Bidder	30
30	Foreclosure	30
31	Force majeure	30
	Annexure-A Instruction to Bidders for Online Tendering	32
	Annexure-B List of Banks for submission of EMD	33
	Form PA to PG	35



---

Price Bid Form – PP	42
Format of Bank Guarantee for EMD	47
Annexure-D DRW	50



## TENDER NOTICE

### **Tender Number GMDC/ATPS/BMD Spares-39 21-22**

<b>Place of work</b>	2x125 MW Akrimota Thermal Power Station, village Nanichher, Taluka-Lakhpur, District-Kutch, Gujarat.
<b>Brief Description of work</b>	Supply of Mechanical spares for Boiler at 2x125 MW Akrimota Thermal Power Station
<b>Item wise Quantity.</b>	Actual Quantity mentioned in tender
<b>Period of contract</b>	One Year
<b>Estimated Contract Value</b>	Rs.1,55,82,600.00 (Rupees One Crore Fifty Five Lakh Eighty Two thousand Six Thousand Only) excluding GST.
<b>Availability of Tender</b>	Tender Document will available on the GMDC website (www.gmdcltd.com) and nprocure portal (https://gmdc.nprocure.com). Bids shall be required to be submitted online on the nprocure portal (https://gmdc.nprocure.com).
<b>EMD (Earnest Money Deposit)</b>	Rs. 4,67,478.00 (Rupees Four Lakh Sixty Seven Thousand Four Hundred Seventy Eight Only) in any one of following form ➤ DD in favour of GMDC Ltd. Payable at Ahmedabad. ➤ Fixed Deposit from Banks approved by Govt. Of Gujarat (except Co-operative Bank) duly pledged in favour of GMDC for a period of not less than 6 (six) months from the last date of submission of bid and shall be renewed from time to time in case of requirement. ➤ Bank Guarantee issued by banks approved by Govt. Of Gujarat from time to time (except Co-Operative bank) in the form and manner acceptable to GMDC (Govt. GR is annexed at Annexure-I for approved bank). It should be valid for a period of not less than 6 (six) months from the last date of submission of bid. ➤ Digital Mode, Please note if payment is made through Digital Mode kindly submit the receipt of the same in the attached documents. RTGS details for payment (Annexure-C) ICICI Bank, Ahmedabad Branch, Ahmedabad Account Number: 002405019379 IFSC: ICIC0000024  <i>Relaxation in terms of submission of EMD shall be given to the bidder who is holding valid Certificate issued under the MSME Act, 2006 on the date of submission of Tender.</i>
<b>Tender Processing Fee</b>	Rs. 15000/- (Fifteen Thousand only) plus GST @ 18% aggregating to Rs.17,700/- payable by Demand Draft/ Pay Order drawn in favor of "GMDC Ltd." Payable at Ahmedabad.  <i>Relaxation in terms of submission of Tender Processing Fee shall be</i>



	<i>given to the bidder who is holding valid Certificate issued under the MSME Act, 2006 on the date of submission of Tender.</i>
<b>Commencement of tender</b>	From – 8 <sup>th</sup> March 2022
<b>Last date for download the tender document.</b>	22 <sup>th</sup> March 2022 up to 18:00 hrs
<b>Last date of submission of bid through online</b>	22 <sup>th</sup> March 2022 up to 18:00 hrs
<b>Last date of submission of physical documents i.e. EMD, Tender Fee etc.</b>	22 <sup>th</sup> March 2022 up to 18:00 hrs at Corporate Office, GMDC, Ahmedabad
<b>Date and time for online opening of preliminary bid.</b>	22 <sup>th</sup> March 2022 at 18:30 hrs
<b>General and Important Terms and Conditions</b>	<ol style="list-style-type: none"><li>1. GMDC reserves absolute right/discretion to accept and/or reject any or all the tenders received or invite fresh bid at any stage or split the work between more than one Bidders as the case may be.</li><li>2. The Bidders are required to quote the rate strictly as per the terms and conditions mentioned in the Tender document. Conditional tender shall not be entertained and will be rejected summarily without assigning any reasons, whatsoever.</li><li>3. GMDC may issue amendments/corrigendum in the tender documents, schedule, forms etc. at any time during the period between publication of notice and submission of bids of the tender on website. The Bidders in their own interest are advised to visit the website regularly till the last date of submission of the bid. No separate newspaper advertisement will be released for amendments/corrigendum.</li><li>4. GMDC reserves the rights to modify or alter any Condition of the Tender.</li><li>5. The Bidders are advised to submit their price bid online on <a href="https://www.gmdc.nprocure.comonly">https://www.gmdc.nprocure.comonly</a>. Physical price bid shall not be accepted and shall be rejected summarily without assigning any reasons, whatsoever.</li><li>6. Failure to submit bid online in stipulated time due to any reason whatsoever by any Bidder shall result in disqualification of bid. In such circumstances, bid submitted physically along with supporting documents, tender processing fees, EMD amount etc. shall not be considered as bid submitted and the same will be returned back to the Bidder without opening the same. GMDC reserves the right to take suitable decision in this regard.</li></ol>



## **1. Purpose of the Document**

The Request for Proposal (this document) floated by GMDC (Gujarat Mineral Development Corporation Limited), A Government of Gujarat Enterprise is to select a Bidder which would be responsible to Supply of Mechanical spares for Boiler of 2x125 MW Akrimota Thermal Power Station the quoted commercials and executed contract terms & conditions.

## **2. About GMDC**

Gujarat Mineral Development Corporation Limited herein after referred to as GMDC, a Government of Gujarat Enterprise, is a pioneer company in the field of mining for more than five decades, catering to the needs of the minerals and solid fuel for the industries based in Gujarat. GMDC's mining activities are spread all over Gujarat. It is currently dealing in minerals like Lignite, Bauxite, Fluorspar, Ball Clay, Silica sand and Manganese. GMDC has also set up a 250 MW lignite based Thermal Power Station at NaniChher in Kutch, Wind power plant of 200 MW at Maliya, Jodiya, Godsar, Bhanvad, Bada, Varvada, Rojmal and Solar Power plant of 5 MW at Panandhro Project.

## **3. Location of Work**

The work to be carried out at Akrimota Thermal Power Plant Station (ATPS), located at Village NaniChher of LakhpatTaluka in Kutch District of the Gujarat State. The project is located about 150 kms from Bhuj. The nearest Railway Station and Airport is at Bhuj.

## **4. About ATPS**

GMDC has 2\*125 MW Thermal Power Project called ATPS. Both the units have been in commercial operation since March, 2005. It is getting Lignite from its own mines located at Mata no Madh and Umarsar. The water requirement for the power plant is taken from the nearest Kori Creek through a 1.4 KM long sea water intake channel. The CFBC boiler is used here as it is environment friendly and controls sulphur in the flue gas emission. A 100 metre thick green belt surrounds the entire site. The state of the art technology DCS has been used.

## **5. General Instructions to Bidder**

The section aims to provide guidelines/Instructions for Bidders, to be used while submitting the Proposals.

### **5.1 Cost of Bidding**

The Bidder will bear all costs associated with the preparation and submission of its bid and GMDC LTD., will in no event or circumstance be held responsible or liable for these costs, regardless of the conduct or outcome of the bidding process.

### **5.2 Due Diligence**

The Bidder is expected to and shall be deemed to have examined all instructions, forms, terms and specifications and other information in this Tender Document. The bid should be precise, complete and in the prescribed format as per the requirement of the Tender Document. Failure to furnish all information required by the Tender Document or submission of a bid not responsive to the Tender Document in every respect will be at the Bidder's risk and may result in rejection of the bid. GMDC LTD. shall at its sole discretion be entitled to determine the adequacy/ sufficiency of the information provided by the Bidder.

### **5.3 Clarification of Bidding Documents**

GMDC LTD. shall make best efforts to respond to any request for clarification of the Tender Document. The response/clarification shall to the extent possible be made in writing.

### **5.4 Amendment of Tender Document**

At any time before the deadline for submission of bids, GMDC LTD may modify the tender Document for any reason, whether at its own initiative or in response to a clarification requested by a prospective Bidder, modify the Tender Document by amending, modifying and/or supplementing the same. Any amendments/modifications in the tender document would be displayed on GMDC Web Site and all such amendments shall be binding on the Bidder without any further act or deed on GMDC LTD part. In the event of any amendment, GMDC LTD reserves the right to extend the deadline for the submission of the bids, in order to allow prospective Bidder reasonable time in which to take the amendment into account while preparing their bids. GMDC LTD may at its sole discretion, extend this deadline for submission of bids by amending the bid documents.

### **5.5 Contact Details**

All inquiries concerning this procurement are to be addressed to the following:

General Manager (Power)

---

Gujarat Mineral Development Corporation Ltd.  
Khanij Bhavan, 132' Ring Road, University Ground,  
Vastrapur, Ahmedabad 380 052  
☎EPABX :079-27913501, 27913200Extn.No :1760  
E-mail : power@gmdcltd.com , jndave@gmdcltd.co.in

#### **5.6 Language of Bid**

All Proposals and various documents related to these Proposals should be in English Language. All correspondence between GMDC LTD., and the Bidder would also be in English Language. Supporting Documents and Printed Literature furnished by the Bidder may be in another Language provided they are accompanied by an accurate translation in English Language.

#### **5.7 Late Bids**

Any bid received by GMDC LTD., after the deadline for submission of bids prescribed by GMDC LTD., summarily rejected. GMDC LTD. shall not be responsible for any postal delay or non-receipt /non-delivery of the documents. No further correspondence on this subject will be entertained.

#### **5.8 Right to Accept Proposal**

GMDC LTD., reserves the right to accept or reject any Proposal, and to annul the Proposal process and reject all Proposals at any time prior to award of contract, without thereby incurring any liability to the affected Bidder or any obligation to inform the affected Consortium of the grounds for such decision.

#### **5.9 Site Visit**

**5.9.1** Bidders advised to visit the site to study the actual working conditions, before submission of the bid and shall have to submit the site visit declaration in the prescribed format. The information/details given in the tender document are only to describe the magnitude of work and are for mere guidance to the Bidders.

**5.9.2** Any neglect or failure on the part of the Bidder in obtaining necessary and reliable information upon the foregoing or any other matters affecting the contract shall not relieve him from any risks or liabilities or the entire responsibility from completion of the work at the contracted rates and time in strict accordance with the contract documents.

#### **5.10 Period of Validity of Bids**

Bids shall remain valid for 180 days after the date of bid opening prescribed by GMDC LTD, pursuant to the tender schedule mentioned in this document. In exceptional circumstances, GMDC LTD. may solicit the Bidder's consent to an extension of the period of validity. The request and the response thereto shall be made in writing. Extension of validity period by the Bidder shall be unconditional.

#### **5.11 Sub Contract**

The Successful bidder shall not assign or sub-contract any portion of this work without prior written consent of GMDC.

#### **5.12 Consortium / Joint Venture**

Consortium / Joint Venture are not allowed.

#### **5.13 Change in Law**

Nothing in this contract shall entitle the Bidder to claim additional payment against the work executed or being executed or likely to be executed upon the change in law by Government of India or State of Gujarat as regards any taxes, liabilities arising out of work contract, judgments of court etc. That nothing under the said laws shall create any additional liability on the GMDC over and above that set out herein. That unforeseen circumstances in the working of the said contract shall not entitle Successful Bidder to abandon or demand additional payment under a different head not originally mentioned herein and hence nothing except what is contained in the present contract shall constitute binding obligations between parties.

#### **5.14 Interpretation**

That no communication preceding or following the present tender shall have any bearing on the terms and conditions set out herein. That no contract, promise or obligation shall arise out of the said communication, over and above what is set out herein above. That the terms contained herein constitute the entire bargain between the parties and shall not be interpreted in the light of commercial correspondence between the parties.

#### **5.15 Acceptance of All the Terms and Conditions**

The Bidder should submit the declaration regarding unconditional acceptance of all the terms and conditions of the Tender document including Annexure and corrigendum if any as per FORM PD provided in the Tender Document.

#### **5.16 Declaration**

The Bidder should give a declaration that it has not enclosed any conditional offer as per the format provided in FORM PD of the Tender Document.



5.17 GMDC is authorized to take suitable decision and action in case of requirement to amend/alter the contract conditions/quantities of the works/ extension of the contract period/allotment of additional works/revision of the rates of the work etc. if necessary in the interest of GMDC.

5.18 The Successful bidder shall not change the constitution of the firm/name during the currency of the contract without prior approval of GMDC. Upon such change in constitution and/or name, Supplementary agreement to that effect shall be executed and if the SD is submitted in form of BG/FD than fresh BG in the name and/or constitution shall be submitted failing which necessary action as deemed fit by GMDC shall be taken.

## 6. Earnest Money Deposit

A non-interest bearing Earnest Money Deposit Rs. 4,67,478.00 (Rupees Four Lakh Sixty Seven Thousand Four Hundred Seventy Eight Only) in any one of following form

- Demand Draft in favour of GMDC Limited Payable at Ahmedabad.

OR

- Fixed Deposit from Banks approved by Govt. Of Gujarat (except Co-operative Bank) duly pledged in favor of GMDC for a period of not less than 6 (six) months from the last date of submission of bid and shall be renewed from time to time in case of requirement.

OR

- Bank Guarantee issued by banks approved by Govt. Of Gujarat from time to time (except Co-Operative bank) in the form and manner acceptable to GMDC (Govt. GR is annexed at “B” for approved bank). It should be valid for a period of not less than 6 (six) months from the last date of submission of bid.

OR

- Digital Mode, Please note if payment is made through Digital Mode kindly submit the receipt of the same in the attached documents. RTGS details for payment (Annexure-C)  
ICICI Bank, Ahmedabad Branch, Ahmedabad  
Account Number: 002405019379  
IFSC: ICIC0000024

*Relaxation in terms of submission of EMD shall be given to the bidder who is holding valid Certificate issued under the MSME Act, 2006 on the date of submission of Tender.*

## 7. Tender Processing Fee

The Tender Processing Fee is to be paid at the time of submission of supporting document of technical bid in the form of demand draft/ Pay Order of Rs. 15000/- plus GST @ 18% (Rs. 2700)

aggregating Rs 17,700/- as mentioned in tender notice in the sealed technical bid cover. If the amount mentioned in the DD/ Pay Order is found short, the tender will not be considered for scrutiny and will be out rightly rejected.

***Relaxation in terms of submission of Tender Processing Fee shall be given to the bidder who is holding valid Certificate issued under the MSME Act, 2006 on the date of submission of Tender.***

## **8. Security Deposit**

**8.1** Security Deposit is measure of liquidated damages sustained by GMDC for not performing the contract satisfactorily. Nothing herein above shall disentitle GMDC from claiming the damages actually sustained in the value over and above the Security Deposit.

**8.2** The successful bidder shall submit security deposit of 10% of the total contract value excluding Goods & Service Tax (GST) at within 10 days from the date of receipt of LOI in any one of following form

- Demand Draft in favor of GMDC Limited Payable at Ahmedabad.

OR

- Fixed Deposit from Banks approved by Govt. Of Gujarat (except Co-operative Bank) duly pledged in favor of GMDC for a period of not less than 18 (Eighteen months) months from the date of receipt of LOI and shall be renewed from time to time in case of requirement.

OR

- Bank Guarantee issued by banks approved by Govt. Of Gujarat from time to time (except Co-Operative bank) in the form and manner acceptable to GMDC (Govt. GR is annexed at “B” for approved bank). It should be valid for a period of not less than 18 (Eighteen months) from the date of receipt of LOI and shall be renewed from time to time in case of requirement.

**8.3** It shall be refunded to the Successful bidder, within a period of six months after satisfactory completion of the work and removal of equipment, tools tackles, campsite etc, and the due fulfillment of all the terms and conditions of the contract.

**8.4** The Successful bidder shall obtain “No Dues Certificate” and “Site Clearance “certificate to this effect from the General Manager [Project] / Project-in-Charge and shall submit the same



to the General Manager [Power] at HO, who after verification of the fact will arrange for refund of SD.

- 8.5 The successful bidder will also have to submit “NO DEMAND CERTIFICATE” along with the above mentioned certificate.
- 8.6 The SD deposited by the Successful bidder may be forfeited if the successful bidder fails to adhere to fulfill the conditions of work order / agreement.
- 8.7 Security deposit shall not bear any interest under any circumstances. Security Deposit is a measure of liquidated Damages sustained by GMDC for not providing the manpower, tools and tackles as required as per the contract.
- 8.8 GMDC will reserve the right to recover the charges or the liquidated damages from the Security Deposit in the following circumstances-
  - 8.8.1 If the successful bidder or its employees causes any damage or destroy any property belonging to GMDC.
  - 8.8.2 The shortfall amount of all compensations, penalties and other sums of money payable by the successful bidder or recoveries to be made under the terms of this contract which is due but not paid by the successful bidder in full, etc.
  - 8.8.3 Any other dues on account of statutory compliance.

## 9. Procedure for Submission of the Bid

- 9.1 Offers prepared in accordance with the procedures enumerated below.
- 9.2 Bid should be submitted **online** at [www.nprocure.com](http://www.nprocure.com) on or before the last date and time as prescribed in this tender.
- 9.3 The Bidder should submit their bids in THREE parts, these are
  - 9.3.1 Pre qualification bid (Details of EMD and Tender Processing Fee),
  - 9.3.2 Technical Bid
  - 9.3.3 Price Bid.
- 9.4 Manual price bids or the bids submitted by telex/ telegram/ fax/ e-mail etc. will not be accepted under any circumstances. No correspondence will be entertained on this matter.
- 9.5 Bidders are advised to follow the ‘Instructions for Bids Submission’ given annexure “A” for e-submission of the bids online through n-procure.

Documents should be submitted as per check list given in form “PA” through ‘off-line’ in the sealed cover super-scribed as “Technical Bid for Tender Number GMDC/ATPS/BMD Spares - 39/21-22 and Name of work: “Supply of Mechanical spares for Boiler at 2x125 MW Akrimota Thermal Power Station” Bids must be submitted as per the schedule (date & time) indicated in tender notice.

## 10. Eligibility and Qualification Criteria of Bidder

### 10.1 Experience

**10.1.1** The Bidders should have following minimum experience of having successfully completed similar works during last 7 (seven) years ending on last day of December 2021 (i.e. period from 01.01.2015 to 31.12.2021)

A. Three similar completed works each having amount of Rs 62.33 Lacs (Sixty Two Lakhs Thirty three Thousand Only) or more during last 7 (seven) years.

**OR**

B. Two similar completed works each having amount of Rs 77.91 Lacs (Rupees Seventy Seven Lakhs Ninety One Thousand Only) or more during last 7 (seven) years.

**OR**

C. One similar completed work having amount of Rs 124.66 Lacs (Rupees One Crore Twenty Four Lakhs Sixty Six Thousand Only) or more during last 7 (seven) years.

Similar works means the Bidders should have Experience of:

Supply of Spares of any Power Plant OR any Industries and carried out under single LOI/Work order/ Agreement **OR**

AMC of any Power Plant OR any Industries and carried out under single LOI/Work order/ Agreement **OR**

ARC of any Power Plant OR any Industries and carried out under single LOI/Work order/ Agreement **OR**

O&M Services of any Power Plant OR any Industries and carried out under single LOI/Work order/ Agreement **OR**

Maintenance of any Power Plant OR any Industries and carried out under single LOI/Work order/ Agreement **OR**

Supply of Technical manpower of any Power Plant OR any Industries and carried out under single LOI/Work order/ Agreement **OR**

Annual overhauling of equipment of any Power Plant OR any Industries and carried out under single LOI/Work order/ Agreement.

## **10.2 Financial**

**10.2.1** Bidder must have an average positive Net Worth for last for financial year of 2017-18, 2018-19 and 2019- 20.

**10.2.2** Bidder must have a Minimum Average Turnover of Rs. 46.75 Lakh (Forty six Lakh Seventy Five Thousand Only) for financial year of 2018-19, 2019- 20 and 2020-21.

A certificate from Chartered Accountant regarding Financial capacity shall be submitted as per format provided in FORM PC of the Tender Document.

### **1.1 Site Visit Certificate**

The Bidder should give a declaration of site visit as per the format provided in **FORM PG** of the Tender Document.

### **1.2 Blacklisting of the Bidder**

The Bidder or its directors have not been blacklisted by any Government Organization, nor should any litigation be pending against any of them. The Bidder will submit a declaration to this effect as per the format provided in **FORM PD** of the Tender Document. If at any time such declaration is found false, the bid will be rejected or if the contract work is already awarded, it will be terminated forthwith without payment of any compensation and the EMD/SD will be forfeited.



## 11.Scope of Work

The Contract validity shall be for one year. Supply of spares shall be reached to site within 16 week from acceptance of LOI from GMDC.

**At ATPS following spares supply by Successful bidder:**

SR.NO	DESCRIPTION OF SPARES/MATERIAL	UNIT	ESTIMATED QUANTITY
<b>BOILER SPARES</b>			
1	LOCATING (DE) FOR SA FAN BEARING WITH HOUSING. FAN SIZE/TYPE:2030 MM DIA DIBAB-11 SA FAN, BEARING SIZE/TYPE: 4.1/2" DIA RI TYPE WATER COOL SHAFT DIA. AT BEARING:101.6MM, TYPE: JOURNAL, MATERIAL:CAST IRON, LINER MATERIAL:WHITE METAL.	NO.	1
2	Anchor 420x25x5mm, MOC:SS 310 as per drawing.	NOS	700
3	Anchor 320x25x5mm, MOC:SS 310 as per drawing.	NOS	350
4	Anchor 220x25x5mm, MOC:SS 310 as per drawing.	NOS	250
5	Lithium grease EP2 TYPE ( Servo )	KG	364
6	Servomesh SP-320 oil	LITR	420
7	Helical gear, Part No.51 with pinion shaft, part No.41, Dia-306mm, Application: Gravimetric feeder gearbox.	SET	4
8	Helical gear, Part No.52, with 02 nos pinion shaft, Part No.42, Gear OD-254.40mm, No. of teeth-83, Pinion OD-47 mm, No. of teeth-13,Application: Gravimetric feeder gearbox.	SET	4
9	Input pinion shaft OD-76mm, Length-231.7mm, MOC-EN-8 as per drawing with distance piece, Size:ø65xø75x33mm and external circlip DIN 471 65X2.5 mm	SET	4
10	Bevel gear part No.53 with pinion shaft part No.43, Application: Gravimetric feeder gearbox.	SET	4
11	Output shaft sleeve with 02 nos ke, sleeve size: ID-92mm, OD-145mm, length-431mm, key size:28x28x104mm, key size:22x20x431 as per drawing.	NOS	4
12	Bearing 6026, Make: SKF	NOS	8
13	Bearing 32311 J2,Make: SKF	NOS.	8
14	Bearing 32312 J2Q, Make: SKF	NOS	8
15	Bearing 6313 Z, Make: SKF	NOS.	4
16	Bearing 6405, Make: SKF	NOS.	4
17	OIL SEAL 130X160X15, Make: SKF	NOS	16
18	OIL SEAL 65X90X10, Make: SKF	NOS.	4



19	Pulley head lagged material conveyor GRP LPG 30 Schenck process part No.AB16268-1, <b>Application: Gravimetric feeder head end pulley</b>	NOS	2
20	Self cleaning screw pulley, Size:cage OD-365mm, Cage thickness-12mm, length-1074mm, Material-EN-8, Shaft OD-72 mm, length-1162mm Material-EN-19 as per drawing, <b>Application: Gravimetric feeder tail end side.</b>	NOS	2
21	COC chain link assembly as per drawing No.1.47740/00885-0207 <b>with flight</b> (Link MOC-DIN1720 20 Mn CR5 RC-60, Pin-18C Ni8 BHN 250 to 280, Circlip MOC: SS 304, Rib-ST 35 Carbon steel.	SET	42
22	COC chain link assembly as per attached drawing <b>without flight</b> ( Link MOC-DIN1720 20 Mn CR5 RC-60, Pin-18C Ni8 BHN 250 to 280, Circlip MOC: SS 304.	SET	378
23	MS CHANNEL, SIZE:1010X75X35X5 MM	NOS	18
24	MS FLAT PLATE, SIZE:1010X55X10MM	NOS	18
25	MS FLAT PLATE, SIZE:1010X40X10MM	NOS	24
26	MS FLAT PLATE, SIZE:1010X30X10MM	NOS	36
27	MS FLAT PLATE, SIZE:1010X45X10MM	NOS	24
28	RECTANGLE BAR, SIZE:1010X12X10MM	NOS	12
29	SPECIAL BOLT WITH NUT MOC-SS 304 AND TRAVELLING ROLLER, MOC-SS 304 AS PER DRAWING.	SET	60
30	SS BOLT SIZE:8X65MM WITH DOUBLE NUT AND WASHER.	NOS	216
31	MS CHANNEL, SIZE:140X75X9X1130 MM	NOS	12
32	MS CHANNEL, SIZE:140X75X9X1330 MM	NOS	12
33	NON ASBESTOSE CERAMIC ROUND ROPE INCONEL WIRE BRAIDED, SIZE:16 MM, TEMPERATURE:1200 DEGREE.	KG	30
34	SLIDING MANUAL GATE FOR RALF, EFFECTIVESIZE-1000*500MM,EFFECTIVE TEMP-500°C, PRESSURE-0.7 BAR, MEDIA-LIGNITE AND AIR AS PER DRAWING 1.47740/00300-0092(GATE SHOULD BE SINGLE OPERATED SPINDLE)	NOS	2
35	LANCE TUBE ASSEMBLY, MODEL NO.IK-300, FULL TRAVEL SOOT BLOWER MOC-T11 FOR LRSB	NOS	1
36	LANCE TUBE ASSEMBLY, MODEL NO.IK-300, HALF TRAVEL SOOT BLOWER MOC-T11 FOR HRSB	NOS	1



37	Tube, Size:31.8mm ODX4.2mm thickX9000mm, MOC:SA 210 Gr.A1 HFS 1998 with Addenda 1999, For 2nd pass From Wall tubes with IBR certificate and material test certificate (Original)	MTR	50
38	WATER WALL TUBE, SIZE:57.1X8.1X12000MM, MOC:SA210 GR.A1 HFS 1998 WITH ADDENDA:1998 WITH IBR CERTIFICATE AND MATERIAL CERTIFICATE (ORIGINAL)	MTR	50
39	Shield for backpass hanger tube as per attached drawing and MOC.	NOS	200
40	Shield for backpass SH-1 inlet hanger tube as per attached drawing and MOC.	NOS	200
41	CONVEYOR CHAIN AS FORGED FORK LINK CHAIN MADE OF 20MnCr5 EQUIPPED WITH SCRAPER EVERY 142 MM FOR ASH DRAGLINK CONVEYOR	NOS	356
42	GUIDE PLATE, SIZE:75X12X1700MM, MOC: RST-37-2 FOR ASH DRAGLINK CONVEYOR.	NOS	64
43	BEARING 22215 EK, MAKE: SKF	NOS	4
44	SLEEVE H-315, MAKE: SKF	NOS	4
45	LOCATING RING, FRB 12.5x130 FOR BEARING 22215, MAKE: SKF	NOS	8
46	HEAD END SPROCKET FOR ASH DRAGLINK CONVEYOR AS SAMPLE	NOS	2
47	TAIL END SPROCKET FOR ASH DRAGLINK CONVEYOR AS SAMPLE	NOS	2
48	MS ANGLE 75X75X6	TON	1
49	PLATE, MOC:MS, THICK-8 MM, STD SIZE	TON	2
50	ASH RECIRCULATION NON METALLIC BELLOW, BOLSTER WITH FABRIC PORTION VERTICAL FLANGE DESIGN SIZE:4000 MM LONGX FLANGE TO FLANGE 400 MM WIDTH 850 DEG C TEMP FLANGE SIZE:100 MM, PIPE DIA-1125 FOR ASH RC LINE.	NOS	1
51	NMEJ BELLOW FOR CYCLONE INLET DUCT LENGTH 23000 MM X WIDTH 650 MM. TYPE:40X-W,4041X6688 MM, TEMP:1100 DEG, MEDIA: FLUE GAS+ASH+SULPHUR, APPLICATION: CYCLONE INLET DUCT, MAKE: KELD	NO	2
52	MS PLATE, MOC:MS, THICK-6 MM, STD SIZE	MT	10
53	PLATE, MOC:MS, THICK-4MM, STD SIZE FOR SA FAN CANOPY FABRICATION.	TON	1
54	PLATE, MOC:MS, THICK-4MM, STD SIZE FOR PA FAN CANOPY FABRICATION.	TON	1



55	LIGNITE DRAGLINK CHAIN LINK ASSEMBLY INCLUDING CIRCLIP, PIN FLIGHT BAR, SS BOLTS AND NYLOCK NUT ETC. AS PER DRAWING.	SET	198
56	DUPLEX SPROCKET, DRIVE TYPE, ID: 60 MM, KEY WAY: 18 MM X 6MM, PITCH:1.25 ", TEETH: 19, MOC: C45/EN-8, FLAME HARDENED MIN.300 BHN, APPLICATION:LIGNITE DRAGLINK CONVEYOR DRIVE SPROCKET	NOS	4
57	DUPLEX SPROCKET, DRIVEN TYPE, ID: 180 MM, PITCH: 1.25 ", TEETH: 42, MOC:C45/EN-8, FLAME HARDENED MIN.250 TO 300 BHN., APPLICATION: LIGNITE DRAGLINK CONVEYOR DRIVEN SPROCKET	NOS	4
58	PHC 20 B-2X10 FT BS ROLLER CHAIN, MAKE: SKF	NOS	6
59	FORKY SPROCKET,OD-480MM,PCD-265MM,ID-235MM,THICKNESS-20MM,MOC-EN-19,TEETH SURFACE HARD 45HRC, FOR LIGNITE DRAGLINK AS PER DRAWING(1 SET=02 DISC),MAKE-ROLCON,APPLICATION-LIGNITE DRAGLINK CONVEYOR	SET	4
60	GUIDE PULLEY AS PER ATTACHED DRAWING FOR LIGNITE DRAGLINK CONVEYOR (FOR ONE LIGNITE DRAGLINK) 1SET=2Number	SET	1
61	ONLY GEAR MECHANISM FOR MODEL NO. R97DV132M4/TF-RATED, REDUCTION RATIO: 59.92, POWER: 7.5 KW, MAKE: SEW EURODRIVE , FOR LIGNITE DRAGLINK CONVEYOR GEARBOX	NOS	1
62	ANGLE, MOC:MS, SIZE:75X100X8MM. 6 MTR LENGTH-01 NO.	TON	2
63	PLATE, MOC:SS 304 THICK: 5 MM, STD SIZE	TON	2
64	PLATE, MOC:MS, THICK:4 MM, STD SIZE	TON	2
65	PLATE, MOC:MS, THICK:8 MM, STD SIZE	TON	1
66	PLATE, MOC: MS, 8MM THICK, STD SIZE	TON	1
67	PLATE, MOC: SS 310, 8MM THICK, STD SIZE	TON	0.8
68	CASING COVER, PART NO.161, MOC: CI, PUMP MODEL No. ETN 80-250 GC, MAKE- KSB, APPLICATION: HOT WATER PUMP	NOS	4



69	SHAFT PART NO.210,MOC-410,MOC: CI, PUMP MODEL No. ETN 80-250 GC, MAKE- KSB, APPLICATION: HOT WATER PUMP	NOS	4
70	CASING WEAR RING , PART NO.502.1, MOC-CF8M,PUMP MODEL No. ETN 80-250 GC, MAKE- KSB, APPLICATION: HOT WATER PUMP	NOS	4
71	CASING WEARRING,PART NO.502.2,MOC-CF8M,PUMP MODEL No. ETN 80-250 GC, MAKE- KSB, APPLICATION: HOT WATER PUMP	NOS	4
72	SHAFT SLEEVE-GLAND PACKING , PART NO.524, MOC-410 H , PUMP MODEL No. ETN 80-250 GC, MAKE- KSB, APPLICATION: HOT WATER PUMP	NOS	4
73	IMPELLER , PART NO..230,MOC-CF 8M, PUMP MODEL No. ETN 80-250 GC, MAKE- KSB, APPLICATION: HOT WATER PUMP	NOS	4
74	VOLUTE CASING, PART NO.102, MOC-CI, PUMP MODEL No. ETN 80-250 GC, MAKE- KSB, APPLICATION: HOT WATER PUMP	NOS	4
75	IMPELLER FOR 1270 MM DIA SIPSC -05, FAN TIP SPED 198.16MM/SEC ,FAN RPM 2890 MAKE : ANDREW & YULE OR EQUIVALENT CO , APPLICATION :ASH COOLER FAN	NOS	1

- 11.1 Reference Drawings are attached in annexure for bid purpose only successful bidder has to develop drawings for the items of supply and got approved from GMDC. Bidder has to approve sample of material before bulk supply. Bidder has to give interchangeability & fitment guarantee/warranty for all developed supplied material.
- 11.2 Prospective bidder may visit at site for inspection of item to be quoted. For quote purpose Bidder has to take dimensions for fitment guarantee & collect sample of material for ascertaining MOC
- 11.3 Reference drawings for the above items are attached in annexure herewith for bid purpose. Successful bidder shall be given sample for reference for manufacturing purpose on returnable basis.
- 11.4 The bidder shall have to supply the above spares as per the specifications otherwise shall be rejected.
- 11.5 Bidder shall submit all kind of test certificate for chemical composition and mechanical properties of the supplied each materials.

- 11.6 Bidder has to supply one sample along with drawing of each item for approval to GMDC, and after getting approval, shall supply balance quantity. Information to be given to GMDC well in advance.
- 11.7 GMDC has right to conduct any test of all spares, if required from Govt. Approved laboratory and results of same shall be binding to bidder. Bidder may witness the same.
- 11.8 Bidders need to supply OEM/OES spares with required certificate.
- 11.9 Quantity of supply items may increase or decrease as per requirement of ATPS, it should be increase 10% of total contract value.
- 11.10 Unloading, lifting, shifting and item code specifying and arrangement of supplied materials at designated location inside ATPS shall be in bidder's scope.

## **12. Measurements**

- 12.1 Supply of spares, equipments & Materials as per scope of supply shall be counted for payment, If the supply is not completed as per scope of supply and any part supply is done, then the part supply shall not be counted for payment.
- 12.2 Material test certificate of all supplied spare along with material.

## **13. Liquidated Damages (LD)**

- 13.1 LD for late supply of spare shall be liable for any delay beyond delivery period specified in the tender @ 0.1% per day of particular items in tender document.
- 13.2 Under any circumstances, GMDC shall not be liable to pay any compensation to the Successful bidder.
- 13.3 Overall cap on the total LD shall be 5 % of the contract value.

## **14. Performance Guarantee:**

- 14.1 For all supplied material, successful bidder shall abide to accept the clause for the satisfactory performance of the supplied materials with guarantee of 12 months from date of commissioning or 18 months from the date of supply whichever is earlier.

## **15. Goods & Service Tax**

- 15.1 All bidders are required to submit their GST number and date in the bid. Bid received from unregistered bidder will not be considered and out rightly rejected.

**15.2** Bidders are requested to quote their rates without GST. GST will be paid/adjusted/reimbursed to the Successful bidder as per prevailing rates and rules to the extent directly related to the services rendered OR Goods supplied by the Successful bidder under the said contract subject to production of documentary proof and Successful bidder will mention the GST amount separately in the invoice/bill along with SAC/HSN Code under GST.

## **16. Insurance**

- 16.1** Insurance –The Successful bidder shall take full responsibility to take all precautions to prevent loss or damage to the works or part thereof for any reasons whatsoever (except for reasons which are beyond control of the Successful bidder or act of God, e.g. flood, riots, war, earthquake, etc.) and shall at his own cost, repair and make good the loss/damage to the work so that on completion, the work shall be in good order and condition and in conformity with the requirements of the Contract and instructions of the Project Authority, if any.
- 16.2** The Successful bidder shall, at all times during the pendency of the Contract, indemnify the GMDC against all claims, damages or compensation under the provisions of the Employee’s Compensation Act and shall take insurance policy covering all risk, claims, damages or compensation payable under the Employee’s Compensation Act or under any other law relating thereto.
- 16.3** The Successful bidder shall ensure that the insurance policy/policies are kept alive till full expiry of the Contract by timely payment of premiums and shall not be cancelled without the approval of the GMDC. The cost of premiums shall be borne by the Successful bidder and it shall be deemed to have been included in the tendered rate.
- 16.4** In the event of the Successful bidder’s failure to effect or to keep in force the insurance referred to above or any other insurance which the Successful bidder is required to effect under the terms of the Contract, the GMDC may effect and keep in force any such insurance and pay such premium/premiums as may be necessary for that purpose from time to time and recover the amount thus paid from any moneys due by the Successful bidder.

## 17. Payment Terms

- 17.1 The Successful Bidder shall submit bill of supplied all items within 7 days. Running Account Bill shall be processed after issuance of work order only.
- 17.2 Bill shall be submitted to the office of the General Manager (Power Project), ATPS with following documents:
- Single RA bill submission with minimum amount of 20% of contract value of Work Order excluding GST.
  - Details of spares, consumables, equipment & Material supplied with GMDC ATPS Gate Security certification, GMDC store certification & GMDC EIC inspection certificate, test certificate of spares/equipments.
  - Any other documents if any as prescribed by GMDC as and when requires.
- 17.3 The Running Account bills, submitted at the office of General Manager (Power Project) will be processed there considering following deductions
- 17.3.1 Income tax as per provision of Income Tax Act, and other Taxes (and surcharges) applicable in force from time to time
- 17.3.2 Cost of any other services provided / material supplied plus 15% administrative charge, if any, by the GMDC.
- 17.3.3 Liquidated damages,
- 17.3.4 Other deductions, if any.
- 17.4 An ad-hoc payment @ 80% of the payable amount arrived after considering above deduction, will be paid by office of the G.M. [Power Project], within 30 days of submission of the bill along with its details.
- 17.5 The bill shall then be sent to GMDC's Corporate Office at Ahmedabad for verification, auditing and approval. Balance 20% payable amount of Running account bills shall become payable by Project within two weeks of the receipt of the approved bill from Corporate Office.

## 18. Evaluation of Bids

### 18.1 Completeness of Bids

GMDC, will examine the bids to determine whether they are complete, whether they meet all the conditions of the tender Document and Technical Specifications, whether any

computational errors have been made, whether required sureties have been furnished, whether the documents have been properly signed, and whether the Bid Documents are substantially responsive to the requirements of the Tender Document.

### **18.2 Tender Document Clarifications**

The GMDC may at its discretion, seek from any or all bidders, clarifications on his/their bids, including technical information, documents and materials after technical bid opening but before opening of commercial bid.

### **18.3 Rejection of Bid**

A bid that does not meet all eligibility criteria or is not responsive shall be rejected by GMDC. Submission of false or incorrect information, history of delayed work, reports of unprofessional conduct, among other things, shall be sufficient grounds for disqualification in technical bid.

### **18.4 Opening of Bids**

Technical bids will be opened after verification of receipt of payment towards Tender Fee and EMD. The eligible bidders will be able to view the technical bids after opening of technical bid. On verification of the supporting documents; technical qualification of the bidders will be assessed. The eligible bidders will be communicated the date and time of on line opening of price bids by fax or telephone or email or SMS. However, all successful the bidders will be able to view the price bids online on their computers after opening of price bid.

### **18.5 Selection of Bidder**

The contract will be awarded to the bidder who stands L1 in total price. The GMDC reserves its right to reject any or all tenders or split the job between more than one bidders without assigning any reason and thereby without incurring any liability to the affected successful bidder or Bidders or any obligation to inform the affected successful bidder or successful bidder's of the grounds for GMDC Ltd., action/decision.

### **18.6 Negotiation**

It is absolutely essential for the successful bidders to quote the lowest price at the time of making the offer in their own interest. GMDC, however, will have the discretion to choose to enter into any price negotiations or not.

## **18.7 Acceptance of LOI and Award of Contract(Work Order)**

**18.7.1** GMDC, on acceptance of the offer, will issue Letter of Intent to the successful bidder; who will be required to confirm its acceptance of the LOI within 07 days from the date of receipt. If successful bidder does not accept the LOI within stipulated time period, the amount of the EMD paid will be forfeited and necessary further actions may be initiated as may be deemed fit by the GMDC.

**18.7.2** The Successful bidder shall have to submit the Security Deposit with 10 days from acceptance of LOI. The Successful bidder shall submit the Security Deposit in the manner prescribed in this Tender Document. In case of failure to submit the security deposit, the amount of EMD will be forfeited and necessary further actions may be initiated as may be deemed fit by the GMDC.

**18.7.3** GMDC will award the contract(Work Order) to the successful bidder, after the payment of Security Deposit, in token of acceptance of the terms and conditions of the contract, within 30 days from date of LOI. In case of any necessity arising after executing work order and during the execution of the work, which requires alteration/modifications in the agreement, the same can be made in writing after mutual understanding and consent of both the parties.

## **19. Statutory Obligations**

**19.1** That the Successful Bidder shall obtain license under the Bombay Shops and Establishment Act and it shall pay wages and benefits in accordance with the applicable laws and shall not pay less than as notified by the Government Authorities from time to time and shall maintain the employment records as required under applicable laws.

**19.2** That the Successful Bidder shall get his own License under Contract Labour (Regulation and Abolition) Act. It shall be binding to get the same renewed from time to time and shall maintain all the records as per the act.

**19.3** That the Successful Bidder shall be responsible to enroll his employees, deduct, add and deposit in the relevant accounts the contributions as required under the Employees State Insurance Act, 1952 and the Employees Provident Funds and Miscellaneous Provisions Act 1952 and any other enactment's covered under the various applicable labour laws as well as maintain all books of records for the staff and employees deputed by it for this contract such as required under any laws applicable. The Successful Bidder shall also furnish a copy of such statements as documentary proof to the GMDC.



- 19.4** That if the Successful Bidder is not covered under the Employees State Insurance Act, 1952 then it shall be the duty of the Successful Bidder to take appropriate insurance cover under the Workmen Compensation Act and take Group Personal Accident Policy for all the employees deputed at the project site.
- 19.5** The Successful Bidder has to issue to the employee's Identity card with their photos and shall also maintain relevant register.
- 19.6** That the Successful Bidder shall give leave/holiday to its workforce as per the provisions of labour laws applicable.
- 19.7** Every person deployed by the Successful bidder in a plant must wear safety gadgets to be provided by the Successful bidder.
- 19.8** The Successful bidder will be required to obtain License from the office of the Labour Commissioner for the required strength of labour, before commencement of work at site and the same shall be maintained updated and valid throughout the currency of the contract.
- 19.9** If any amount becomes payable by GMDC as a result of any claim or application in terms of the provisions or non-compliance of provision of the any Acts and the Rules and Regulations, By-laws or the Orders made there under, applicable from time to time, such amounts shall be recoverable from the Successful bidder for which GMDC will not be responsible for any compensation.
- 19.10** That the Successful Bidder would obey with all applicable laws and maintain all such necessary records as necessitated under such enactments.
- 19.11** The Successful bidder shall also indemnify the GMDC against any claims, compensations, damages, loss, liquidated damages etc. for breach and / or non-fulfillment of the prevailing Rules and Regulations and other statutory provisions in force from time to time and applicable to the work during the currency of contract.
- 19.12** The Successful bidder shall comply with other statutory provisions of Law. The Successful bidder shall comply with all applicable laws, ordinances, approved standards, rules and regulations, and shall procure all necessary municipal and governmental permits, licenses and inspection and shall pay all fees and charges in connection with the items covered by the contract. The Successful bidder shall serve GMDC harmless as a result of any in factions thereof. Successful bidder will be solely liable for all non-compliances. The following are some of the major Government of India Acts and Regulations to be complied with by the Successful Bidder. The List is illustrative and not exhaustive.

- The Indian Factories Act of 1948 (63 to 1948) and Amendments and Rules (Amended up to date)
- The Electricity Act, 2003 and rules made there under
- The Indian Boiler Regulation Act, 1950 and rules made there under
- The Minimum Wages Act, 1948
- The Employees Compensation Act 1923 and Amendment Act 2010
- The Payment of Wages Act 1936 and Amendment Act 2012
- Payment of Bonus Act 1965 and Amended up to date
- Contract Labour Regulations & Abolition Act 1970
- Interstate Migrant Workmen (Regulations) Act 1979

## **20. Bankruptcy**

If the Successful bidder commits an act of Bankruptcy or goes into liquidation except for construction purposes, or if its business is carried on by a receiver, such receiver, liquidator or any person in whom the contract may become vested shall forthwith give notice thereof in writing to GMDC and in reasonable time during which he shall take all reasonable steps to prevent stoppage of performance of the contract, have the option of carrying out the contract subject to his or their providing such guarantees as may be required by GMDC but not exceeding the value of the work for the time being remaining unexecuted.

In the event of stoppage of performance under the contract, the period of option under this clause shall be decided by GMDC considering the situation, provided that the above option is not exercised, GMDC may terminate the contract by serving notice in writing to the Successful bidder. The power and provision so reserved to GMDC on taking of the work out of the Successful bidder's hands shall apply as far as they may be when the contract is so terminated.

## **21. Notice**

Written notice shall be deemed to have been duly served if delivered to the individual or to Successful bidder or to the Signing Authority of the GMDC from whom it is intended, or if delivered at or sent by mail or post, to the last business address known to him who gives the notice.

## **22. Canvassing Not Permitted**

**22.1** Bidder should not canvass their offer personally or otherwise by approaching the Chairman or the Member of GMDC. If any Bidder wants to make any representation regarding his offer, he should write to the General Manager (Power), if he desires, but personal and oral representations are not permitted.

**22.2** In spite of the above clear instructions, any Bidder is found to canvass his offer or against his competitor's offer through personal approach to the competent authority or the officials of GMDC, their offer will be rejected without assigning any reason and the firm even is black listed.

## **23. Termination Of Contract**

If at any time during the currency of this contract, if any breach occurs due to the reasons attributed to the Successful bidder, GMDC shall be at liberty to terminate this contract without assigning any reasons, whatsoever, for such termination and any losses and/or damages occurring due to such termination shall be borne by the Successful bidder. GMDC shall be entitled to forfeit Security deposits as Liquidated damages.

## **24. Arbitration**

All questions, disputes, differences whatsoever which may at any time arises between the parties to this Tender and subsequent contract in connection with the Tender and subsequent contract or any matter arising out of or in relation thereto, shall be referred to Sole Arbitrator as per the provisions of Arbitration and Conciliation Act, 1996 and subsequent amendment thereto and the venue of arbitration proceedings shall be at Ahmedabad only. The Language of the Arbitration shall be in English only.

## **25. Governing Law**

This Tender and subsequent Contract shall be construed and interpreted in accordance with and governed by the laws of India.

## **26. Jurisdiction**

The matter related to any dispute or difference arising out of this Tender and subsequent contract shall be subject to the exclusive jurisdiction of Court at Ahmedabad only.

## **27. Non Fulfillment of Terms And Condition of The Contract**

- 27.1** If the Successful bidder fails to carry out the work as per terms and conditions of the contract to the satisfaction of the GMDC, GMDC shall be entitled to forfeit the security deposit paid by the Successful bidder. This however, shall not absolve the Successful bidder from his obligation to fulfill the contract. In such event, the GMDC shall have a right to complete and / or to get the work completed at the cost & risk of the Successful bidder and the Successful bidder shall be responsible to pay such cost incurred by the GMDC to complete the work and / or to get the work completed.
- 27.2** Likewise, if the Successful bidder does not fulfill the terms and conditions of the contract and does not carry out the work up to the entire satisfaction of GMDC, GMDC has the right to forthwith terminate the contract at its sole discretion, without assigning any reason, Under such events, the GMDC shall be entitled to forfeit the security deposit paid by the Successful bidder and the GMDC shall have a right to complete the work and / or to get the work completed at the risk and cost of the Successful bidder.
- 27.3** For any reasons, if it is required, the GMDC reserves rights to cancel, terminate, amend and / or alter the contract and / or bifurcate and / or reduce the contract work at any time without giving any notice or reason to the Successful bidder and without incurring any responsibility. For such cases, Successful bidder shall have to take away his labour, tools, tackles, machinery, equipment etc. and shall leave the site at once or shall have to carry out the instructions of the GMDC.

## **28. Completion Of Supply**

- 28.1** Upon the Successful bidder fulfilling the entirety of its obligations under the Contract to the satisfaction of GMDC and subject to terms and conditions of the Contract, it shall become eligible to apply for a Completion Certificate. The General Manger (Power Project) of GMDC shall formally issue the Completion Certificate, after verifying from the completion documents and satisfying himself that the supply under the Contract have been completed in accordance with all the provisions of this Contract. The Successful bidder, after obtaining the Completion Certificate shall become eligible to present the final bill for the supply by it under the Contract.
- 28.2** The Successful bidder shall provide GMDC with any and all documents/records/proofs that may be demanded before issuance of Completion Certificate.

## **29. Accident and Responsibilities of Bidder**

- 29.1** The entire responsibility on account of any accidents, damage or personal injury which may occurred to any of the Successful bidder's vehicles/ equipments or his/its employees or any outside party shall be exclusively that of the Successful bidder and no claim whatsoever shall be entertain by the GMDC on this account. The Successful bidder shall keep the GMDC indemnified from all the consequence.
- 29.2** In the event of any breakdown or accident during the course of any operation, the Successful bidder shall notify the facts to the Project Authority or any other officer immediately present there of such incidence and shall simultaneously make adequate remedial arrangements on his/its own cost and risk and as per the instruction of the Project Authority.
- 29.3** The Successful bidder shall pay all claims, damages and compensation with cost arising out of or resulting there from to the third party(s) and in case the GMDC would be required to face any proceedings all to pay any amount on the aforesaid account, it shall be deemed to have been discharge on behalf of the Successful bidder, the same amount shall be recovered half-an hour rest interval in between. The Successful bidder shall ensure that the attendance of all the supplied manpower shall be taken through biometric attendance machine.

## **30. Foreclosure**

In case of any necessity arising due to local working conditions or any unforeseen reason not in the control of the GMDC or any reason what so ever GMDC shall be at liberty to Fore close the contract without arranging any reasons or notice there for.

## **31. Force Majeure**

- 31.1** Force majeure is herein defined as any cause which is beyond the control of the Successful bidder or the GMDC as the case may be which they could not foresee or with a reasonable amount of diligence could not have foreseen and which substantially affect the performance of the contract, such as:
- 31.2** Natural phenomena such as flood, draughts Cyclone, earthquake and epidemics, declaration of war.

- 
- 31.3** Acts of any government, including but not limited to war, declared or undeclared priorities, quantities, embargoes, providing either party shall within fifteen (15) days from the occurrence of such a cause notify the other in writing of such cases.
- 31.4** The Successful bidder will advise, in the event of his having resort to this clause by a registered letter duly certified by the statutory authorities, the beginning and end of the cause of delay, within fifteen days of the occurrence and cessation of such Force Majeure condition. In the event of delay lasting over two months, if arising out of Force Majeure, the contract may be terminated at the discretion of the GMDC.
- 31.5** For delay arising out of Force Majeure, the Successful bidder will not claim extension in completion date for a period exceeding the period of delay attributable to the causes of force Majeure and neither company nor he Successful bidder shall be liable to pay extra costs (like increase in rates, remobilization, advance, idle charges for labour and machinery etc.) provided it is mutually established that the Force Majeure conditions did actually exist.
- 31.6** If any of the Force Majeure conditions exists in the place of operation of the Successful bidder even at the time of submission of bid, he will categorically specify them in his bid and state whether they have been taken into consideration in their quotations.
- 31.7** The Successful bidder or the GMDC shall not be liable for delays in performing his obligations resulting from any force majeure cause as referred to and/ or defined above. The date of completion will, subject to hereinafter provided, be extended by a reasonable time.

**Annexure "A"**

**Instruction to Bidders for Online Tendering**

- 1 All Bidders must submit their bid online through the website <https://gmdc.nprocure.com>
- 2 Bidders who wish to participate in online tenders will have to procure / should have legally valid Digital Certificate (Class III) as per Information Technology Act-2000, using which they can sign their electronic bids. Bidders can procure the same from any of the license certifying Authority of India or can contact (n) code solutions- a division of GNFC Limited, who are licensed Certifying Authority by Government of India at address mentioned below at clause 5.
- 3 All bids should be digitally signed. For details regarding digital signature certificate and related training involved at the below mentioned address should be contacted:

Address:

**(n)Procure Cell**

**(n)Code solutions A division of GNFC**

**403, GNFC Info-Tower, Bodakdev,Ahmedabad- 380 054 (India)**

**Tel: +91 26857316/17/18 Fax: +91 79 26857321, Toll Free: 1800-233-1010**

**E-mail : nprocure@gnfc.net**

- 4 Kindly take note that, valid Digital Signature Certificates is a must for all the interested Bidders. Online tendering process is not possible without a valid digital signature certificate.
- 5 Interested Bidders are also requested to complete their procedure for taking digital signature certificate in respect to filling of application form, supporting documents with necessary fees at least 3 days before last date of tender submission.
- 6 (n) code solutions reserves the rights to issue digital signature certificate after verification of application forms / supporting documents submitted by Bidder. (n) code solutions is fully authorized to issue digital signature certificate to Bidders.
- 7 Bidders who have no facility to participate in on-line tenders are requested to contact (n) code solutions for the same.
- 8 Free vendor training camp will be organized every Saturday between 4.00 to 5.00 P.M. at (n) code solutions-A Division of GNFC Ltd. at address mentioned above at Clause No. 5 of Chapter No-III. Bidders are requested to take benefit of the same.
- 9 All the correspondence in respect to training, support or digital signature certificate should be addressed to (n) code solutions directly on the above mentioned address. In case the Bidders face any difficulty, they may contact the officials of the GMDC or GNFC on the below mentioned details:

**a. GMDC:**

Contact Person: General Manager (Power)

Contact numbers: 079-27913200/3501 Ext No 1760

E-Mail: power@gmdcltd.com; jndave@gmdcltd.co.in

**b. GNFC:**

Contact Number: 079- 26857316/17/18

E-Mail: nprocure@gnfc.net

**Annexure "B"**

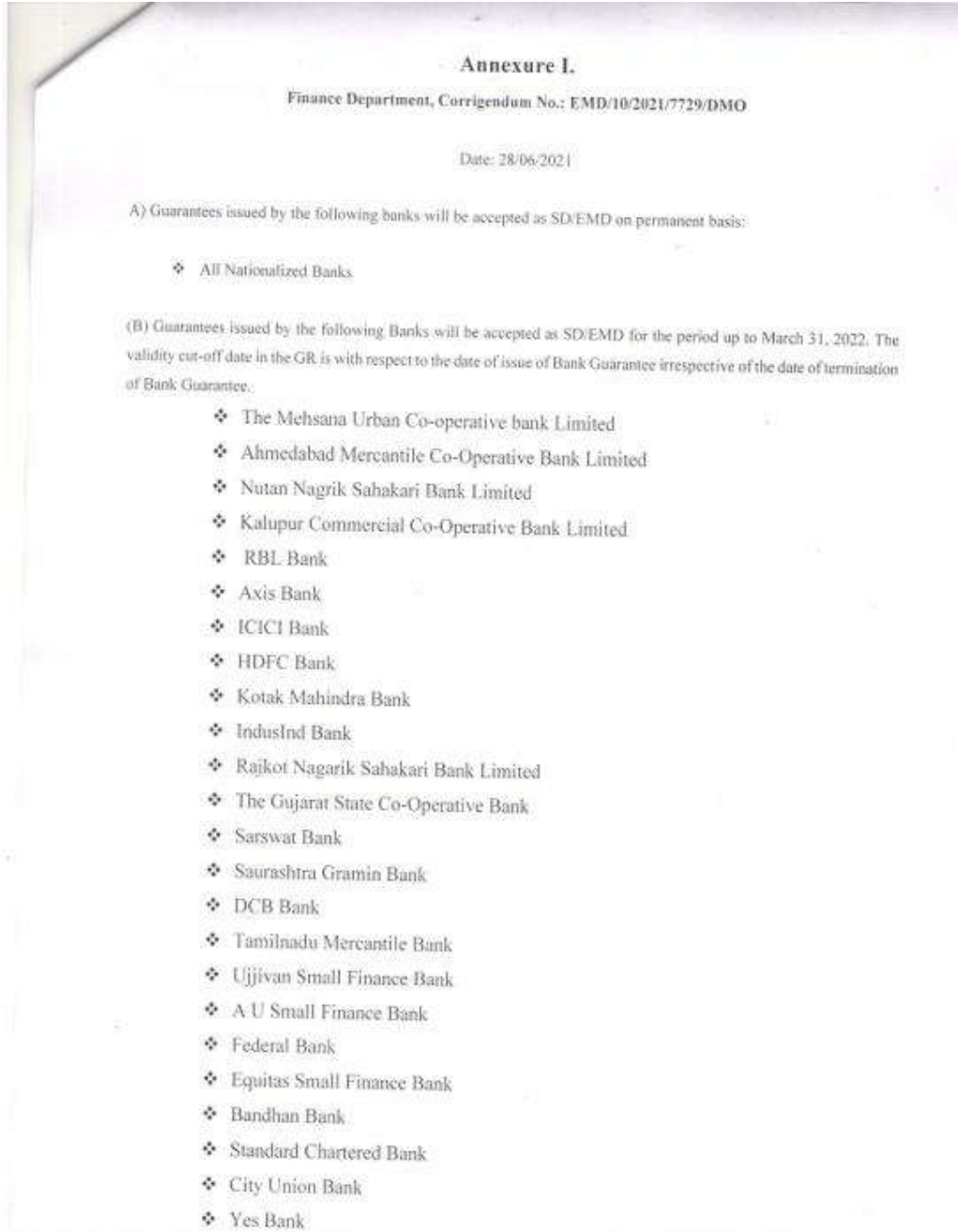

All the eligible banks are instructed to collect the original documents/papers of guarantee from the concerned tendering authority.

  
(S. Chhakenhuak)  
Additional Secretary (B)  
Finance Department



**Annexure "C"**  
**Bank Details for RTGS**

VALID FOR THREE MONTHS ONLY

D D M M Y Y Y Y

OR ORDER

₹

FOR GUJARAT MINERAL DEVELOPMENT LTD

AUTHORISED SIGNATORIES  
Please sign above

*Praveen H. D.*

ICICI Bank  
Ahmedabad Branch  
2nd Floor, Old Baroda Garden Ahmedabad - 380005  
RTGS / NEFT / IFSC Code : ICIC0000024

002405018379

₹ 4,91,099.00

3802290024 019379 29

CAUTION  
BUSINESS BANKING - NEW CURRENT ACCOUNT  
Payable at par at all branches of ICICI Bank Limited in India

BEHARATI



## FORM – PA

### CHECK LIST OF DOCUMENTS ENCLOSED WITH TENDER

#### TECHNICAL BID

Sr. No.	Document	Declaration (Strike out whichever is not applicable)
1.	Tender Processing Fee	Yes/No
2.	EMD	Yes / No
3.	Form PA (check list of documents enclosed with tender)	Yes / No
4.	Form PB (Status of the Bidder)	Yes / No
5.	Form PC (CA Certification for Financial Details and work carried out during the last seven years of bidder)	Yes / No
6.	Form PD (Declarations)	Yes / No
7.	Form PE (Undertaking of Genuineness of Document)	Yes / No
8.	Form PF (Undertaking of Indemnity)	Yes / No
9.	Form PG (Site Visit)	Yes / No
10.	Power of Authority to sign the documents (Duly Notarized on Stamp paper of Rs. 300)	Yes / No

#### PRICE BID

1	Online Price bid submission in Form 'PP'	Yes / No
---	--	----------



**FORM - PB**  
**STATUS OF THE BIDDER**

Particulars	Details
Name of the Bidder:	
Address :	
Registered office :	
For correspondence :	
Telephone No.	
Fax No.	
E-mail Address	
Attested copies of Deeds, Articles of association to be enclosed	
Name & contact number of person holding power of attorney (Attested copy of power of attorney to be enclosed)	
Names of Partners with their Present and permanent address	
Name of Bankers with full address and Telephone No& Bank Account Details (Cancelled Cheque to be enclosed)	
PAN of Bidder	
GST Registration No. of Bidder	
PF Registration No.	
Whether enlisted in other dept., if yes, then furnish the details pertaining to class and the amount qualified to tender	
Was the applicant or its partners or Directors black listed in past by any Govt. or any other body.	
Details pertaining to the work incomplete, if any	
Details of the litigation, court cases and arbitration either completed or under progress during last 10 years by the GMDC entity or any partner/proprietor of present entity GMDC was associated in any capacity.	

Signature and Stamp of the Bidder



## FORM PC

### 1. Turnover and Net Worth

On the basis of the audited books of accounts produced before us by M/s. \_\_\_\_\_, we certify that as per the books of account Net worth and Turn Over of the firm M/s \_\_\_\_\_ are as under:

1.1 Net Worth= Rs. \_\_\_\_\_ for the Year 2018-19  
Rs. \_\_\_\_\_ for the Year 2019-20  
Rs. \_\_\_\_\_ for the Year 2020-21

Average Net Worth

1.2 Turn Over = Rs. \_\_\_\_\_ for the Year 2018-19  
Rs. \_\_\_\_\_ for the Year 2019-20  
Rs. \_\_\_\_\_ for the Year 2020-21

Average Turnover of Rs. \_\_\_\_\_

### 2. Details of Work Carried Out During the Last Seven Years by the Bidder

Sr. No.	Description of work with Work place	Name of client with postal address	Work Order number and date	Contract Period		Actual Quantity worked	Amount without GST of work order	Work experience certificate attached
				From (Date)	To (Date)			
								Yes/No
								Yes/No
								Yes/No
								Yes/No

Signature and Stamp of the Bidder

Signature and Stamp of the CA

TO BE CERTIFIED BY CHARTERED ACCOUNTANT SHOWING  
MEMBERSHIP NO/ FIRM REGISTRATION NO.



---

**FORM PD**  
**Declaration**  
**(On letter head of the Bidder)**

DATE:

To,  
The General Manager (Power),  
Gujarat Mineral Development GMDC Ltd.,  
“KhanijBhavan”, 132 ft. Ring Road,  
University Ground, Vastrapur,  
Ahmedabad-380015

Dear Sir,

I/we here by solemnly declare that

1. Any of our Directors or Partners, jointly or severally and/or individually or our firm/GMDC have not been black listed by the Central Govt. or the State Govt. or its undertakings.
2. We have not put any condition in our offer with respect to Tender No. \_\_\_\_\_,
3. We have accept all the terms and conditions, including Annexure, Corrigendum if any, as specified in the Tender Document No. \_\_\_\_\_ unconditionally.

I/we here by further declare that, if the declaration is found untrue, the GMDC shall be entitled to take any action against us severally and/or individually or our firm/GMDC in this regard in any manner that may be deemed fit by GMDC.

Yours faithfully,

\_\_\_\_\_  
Signature and Stamp of the Bidder



**FORM PE  
(Format for Affidavit)**

**A F F I D A V I T**

**Undertaking Regarding Geniuses Of Documents  
(On Non-Judicial Stamp Paper Of Rs 300/-)**

I/We, \_\_\_\_\_, Partner/Director/Legal Attorney/Accredited  
Representative of M/s. \_\_\_\_\_ solemnly declare that:

1. I/We are submitting Tender for the work \_\_\_\_\_  
\_\_\_\_\_ against Tender No. \_\_\_\_\_
2. None of the Partners/Directors of our firm/GMDC is relative of employee of GMDC.
3. All information furnished by us in respect of fulfillment of eligibility criteria and qualification information of this Tender is complete, correct and true.
4. All documents/credentials submitted along with this Tender are genuine, authentic, true and valid.
5. If it is found at any point of time that our documents are not genuine then in that case our tender will be rejected, earnest money deposited by us will be forfeited and we will be debarred from participating in further/future GMDC tenders and/or any action as deemed fit by GMDC may be taken against us, including termination of the contract, forfeiture of all dues including Earnest Money / Security deposit and banning/delisting of our entity and all related persons etc.

SIGNATURE OF THE BIDDER  
WITH SEAL

Dated .....



---

**FORM PF**

**Undertaking Of Indemnity  
(On Letter head of the Bidder)**

To,

The General Manager (Power)  
Gujarat Mineral Development Corporation Ltd.  
Khanij Bhavan  
132' Ring Road, University Ground,  
Vastrapur,  
Ahmedabad.

Dear Sir,

We M/s. ----- hereby undertake that, we shall at all times, indemnify and keep indemnified that GMDC Limited from any and all liability for damages resulting from or arising out of or in any way connected with the operations covered by the Tender No. \_\_\_\_\_. We shall be responsible for all risk arising in connection with or on account of the operations covered by the contract covered by the above tender and shall make good all losses and damages arising there from. In case, the GMDC Limited shall incur any cost or expense or suffer any loss on account of any claim demand or course of action brought against us and arising out of the operations covered by the Bidder/tender, the GMDC Limited shall have the power (without being bound to do so) to define, contest or compromise any such claim demand or cause of action. Any amount that may become payable by GMDC Limited and any cost expense etc. that may be incurred by the GMDC Limited in this behalf, shall also be recoverable from us, without prejudice to your other rights.

Yours faithfully,  
For -----

(Signature & Stamp of the Bidder)



---

**FORM PG**

**Declaration  
(On letter head of the Bidder)**

**Site Visit**

We \_\_\_\_\_ hereby certify that we have fully understood the site condition in respect of Tender No. \_\_\_\_\_ for all the works mentioned above at \_\_\_\_\_. We have obtained all relevant details, information, data, existing working conditions, existing industrial environment etc. We have also studied the working conditions as proposed in the tender and availability of power supply, water supply, man power, machineries, transportation facility etc.

We hereby agree and undertake not to raise any dispute and/or objection at any stage on any ground whatsoever, during the currency of the contract if awarded to us.

SIGNATURE OF THE BIDDER WITH SEAL

Dated .....



**PRICE BID FORM – PP**  
**(To be submitted online)**

SR.NO	DESCRIPTION OF SPARES/MATERIAL	UNIT	ESTIMATED QUANTITY	Rate in RS. Per Unit	Total Cost
<b>BOILER SPARES</b>					
1	LOCATING (DE) FOR SA FAN BEARING WITH HOUSING. FAN SIZE/TYPER:2030 MM DIA DIBAB-11 SA FAN, BEARING SIZE/TYPER: 4.1/2" DIA RI TYPE WATER COOL SHAFT DIA. AT BEARING:101.6MM, TYPE: JOURNAL, MATERIAL:CAST IRON, LINER MATERIAL:WHITE METAL.	NO.	1		
2	Anchor 420x25x5mm, MOC:SS 310 as per drawing.	NOS	700		
3	Anchor 320x25x5mm, MOC:SS 310 as per drawing.	NOS	350		
4	Anchor 220x25x5mm, MOC:SS 310 as per drawing.	NOS	250		
5	Lithium grease EP2 TYPE ( Servo )	KG	364		
6	Servomesh SP-320 oil	LITR	420		
7	Helical gear, Part No.51 with pinion shaft, part No.41, Dia-306mm, Application: Gravimetric feeder gearbox.	SET	4		
8	Helical gear, Part No.52, with 02 nos pinion shaft, Part No.42, Gear OD-254.40mm, No. of teeth-83, Pinion OD-47 mm, No. of teeth-13,Application: Gravimetric feeder gearbox.	SET	4		
9	Input pinion shaft OD-76mm, Length-231.7mm, MOC-EN-8 as per drawing with distance piece, Size:ø65xø75x33mm and external circlip DIN 471 65X2.5 mm	SET	4		
10	Bevel gear part No.53 with pinion shaft part No.43, Application: Gravimetric feeder gearbox.	SET	4		
11	Output shaft sleeve with 02 nos ke, sleeve size: ID-92mm, OD-145mm, length-431mm, key size:28x28x104mm, key size:22x20x431 as per drawing.	NOS	4		
12	Bearing 6026, Make: SKF	NOS	8		
13	Bearing 32311 J2,Make: SKF	NOS.	8		
14	Bearing 32312 J2Q, Make: SKF	NOS	8		
15	Bearing 6313 Z, Make: SKF	NOS.	4		
16	Bearing 6405, Make: SKF	NOS.	4		
17	OIL SEAL 130X160X15, Make: SKF	NOS	16		
18	OIL SEAL 65X90X10, Make: SKF	NOS.	4		



19	Pulley head lagged material conveyor GRP LPG 30 Schenck process part No.AB16268-1, <b>Application: Gravimetric feeder head end pulley</b>	NOS	2		
20	Self cleaning screw pulley, Size:cage OD-365mm, Cage thickness-12mm, length-1074mm, Material-EN-8, Shaft OD-72 mm, length-1162mm Material-EN-19 as per drawing, <b>Application: Gravimetric feeder tail end side.</b>	NOS	2		
21	COC chain link assembly as per drawing No.1.47740/00885-0207 <b>with flight</b> (Link MOC-DIN1720 20 Mn CR5 RC-60, Pin-18C Ni8 BHN 250 to 280, Circlip MOC: SS 304, Rib-ST 35 Carbon steel.	SET	42		
22	COC chain link assembly as per attached drawing <b>without flight</b> ( Link MOC-DIN1720 20 Mn CR5 RC-60, Pin-18C Ni8 BHN 250 to 280, Circlip MOC: SS 304.	SET	378		
23	MS CHANNEL, SIZE:1010X75X35X5 MM	NOS	18		
24	MS FLAT PLATE, SIZE:1010X55X10MM	NOS	18		
25	MS FLAT PLATE, SIZE:1010X40X10MM	NOS	24		
26	MS FLAT PLATE, SIZE:1010X30X10MM	NOS	36		
27	MS FLAT PLATE, SIZE:1010X45X10MM	NOS	24		
28	RECTANGLE BAR, SIZE:1010X12X10MM	NOS	12		
29	SPECIAL BOLT WITH NUT MOC-SS 304 AND TRAVELLING ROLLER, MOC-SS 304 AS PER DRAWING.	SET	60		
30	SS BOLT SIZE:8X65MM WITH DOUBLE NUT AND WASHER.	NOS	216		
31	MS CHANNEL, SIZE:140X75X9X1130 MM	NOS	12		
32	MS CHANNEL, SIZE:140X75X9X1330 MM	NOS	12		
33	NON ASBESTOSE CERAMIC ROUND ROPE INCONEL WIRE BRAIDED, SIZE:16 MM, TEMPERATURE:1200 DEGREE.	KG	30		
34	SLIDING MANUAL GATE FOR RALF, EFFECTIVESIZE-1000*500MM,EFFECTIVE TEMP-500°C, PRESSURE-0.7 BAR, MEDIA-LIGNITE AND AIR AS PER DRAWING 1.47740/00300-0092(GATE SHOULD BE SINGLE OPERATED SPINDLE)	NOS	2		
35	LANCE TUBE ASSEMBLY, MODEL NO.IK-300, FULL TRAVEL SOOT BLOWER MOC-T11 FOR LRSB	NOS	1		
36	LANCE TUBE ASSEMBLY, MODEL NO.IK-300, HALF TRAVEL SOOT BLOWER MOC-T11 FOR HRSB	NOS	1		



37	Tube, Size:31.8mm ODX4.2mm thickX9000mm, MOC:SA 210 Gr.A1 HFS 1998 with Addenda 1999, For 2nd pass From Wall tubes with IBR certificate and material test certificate (Original)	MTR	50		
38	WATER WALL TUBE, SIZE:57.1X8.1X12000MM, MOC:SA210 GR.A1 HFS 1998 WITH ADDENDA:1998 WITH IBR CERTIFICATE AND MATERIAL CERTIFICATE (ORIGINAL)	MTR	50		
39	Shield for backpass hanger tube as per attached drawing and MOC.	NOS	200		
40	Shield for backpass SH-1 inlet hanger tube as per attached drawing and MOC.	NOS	200		
41	CONVEYOR CHAIN AS FORGED FORK LINK CHAIN MADE OF 20MnCr5 EQUIPPED WITH SCRAPER EVERY 142 MM FOR ASH DRAGLINK CONVEYOR	NOS	356		
42	GUIDE PLATE, SIZE:75X12X1700MM, MOC: RST-37-2 FOR ASH DRAGLINK CONVEYOR.	NOS	64		
43	BEARING 22215 EK, MAKE: SKF	NOS	4		
44	SLEEVE H-315, MAKE: SKF	NOS	4		
45	LOCATING RING, FRB 12.5x130 FOR BEARING 22215, MAKE: SKF	NOS	8		
46	HEAD END SPROCKET FOR ASH DRAGLINK CONVEYOR AS SAMPLE	NOS	2		
47	TAIL END SPROCKET FOR ASH DRAGLINK CONVEYOR AS SAMPLE	NOS	2		
48	MS ANGLE 75X75X6	TON	1		
49	PLATE, MOC:MS, THICK-8 MM, STD SIZE	TON	2		
50	ASH RECIRCULATION NON METALLIC BELLOW, BOLSTER WITH FABRIC PORTION VERTICAL FLANGE DESIGN SIZE:4000 MM LONGX FLANGE TO FLANGE 400 MM WIDTH 850 DEG C TEMP FLANGE SIZE:100 MM, PIPE DIA-1125 FOR ASH RC LINE.	NOS	1		
51	NMEJ BELLOW FOR CYCLONE INLET DUCT LENGTH 23000 MM X WIDTH 650 MM. TYPE:40X-W,4041X6688 MM, TEMP:1100 DEG, MEDIA: FLUE GAS+ASH+SULPHER, APPLICATION: CYCLONE INLET DUCT, MAKE: KELD	NO	2		
52	MS PLATE, MOC:MS, THICK-6 MM, STD SIZE	MT	10		
53	PLATE, MOC:MS, THICK-4MM, STD SIZE FOR SA FAN CANOPY FABRICATION.	TON	1		
54	PLATE, MOC:MS, THICK-4MM, STD SIZE FOR PA FAN CANOPY FABRICATION.	TON	1		



55	LIGNITE DRAGLINK CHAIN LINK ASSEMBLY INCLUDING CIRCLIP, PIN FLIGHT BAR, SS BOLTS AND NYLOCK NUT ETC. AS PER DRAWING.	SET	198		
56	DUPLEX SPROCKET, DRIVE TYPE, ID: 60 MM, KEY WAY: 18 MM X 6MM, PITCH:1.25 ", TEETH: 19, MOC: C45/EN-8, FLAME HARDENED MIN.300 BHN, APPLICATION:LIGNITE DRAGLINK CONVEYOR DRIVE SPROCKET	NOS	4		
57	DUPLEX SPROCKET, DRIVEN TYPE, ID: 180 MM, PITCH: 1.25 ", TEETH: 42, MOC:C45/EN-8, FLAME HARDENED MIN.250 TO 300 BHN., APPLICATION: LIGNITE DRAGLINK CONVEYOR DRIVEN SPROCKET	NOS	4		
58	PHC 20 B-2X10 FT BS ROLLER CHAIN, MAKE: SKF	NOS	6		
59	FORKY SPROCKET,OD-480MM,PCD-265MM,ID-235MM,THICKNESS-20MM,MOC-EN-19,TEETH SURFACE HARD 45HRC, FOR LIGNITE DRAGLINK AS PER DRAWING(1 SET=02 DISC),MAKE-ROLCON,APPLICATION-LIGNITE DRAGLINK CONVEYOR	SET	4		
60	GUIDE PULLEY AS PER ATTACHED DRAWING FOR LIGNITE DRAGLINK CONVEYOR (FOR ONE LIGNITE DRAGLINK) 1SET=2Number	SET	1		
61	ONLY GEAR MECHANISM FOR MODEL NO. R97DV132M4/TF-RATED, REDUCTION RATIO: 59.92, POWER: 7.5 KW, MAKE: SEW EURODRIVE , FOR LIGNITE DRAGLINK CONVEYOR GEARBOX	NOS	1		
62	ANGLE, MOC:MS, SIZE:75X100X8MM. 6 MTR LENGTH-01 NO.	TON	2		
63	PLATE, MOC:SS 304 THICK: 5 MM, STD SIZE	TON	2		
64	PLATE, MOC:MS, THICK:4 MM, STD SIZE	TON	2		
65	PLATE, MOC:MS, THICK:8 MM, STD SIZE	TON	1		
66	PLATE, MOC: MS, 8MM THICK, STD SIZE	TON	1		
67	PLATE, MOC: SS 310, 8MM THICK, STD SIZE	TON	0.8		
68	CASING COVER, PART NO.161, MOC: CI, PUMP MODEL No. ETN 80-250 GC, MAKE-KSB, APPLICATION: HOT WATER PUMP	NOS	4		



69	SHAFT PART NO.210,MOC-410,MOC: CI, PUMP MODEL No. ETN 80-250 GC, MAKE- KSB, APPLICATION: HOT WATER PUMP	NOS	4		
70	CASING WEAR RING , PART NO.502.1, MOC- CF8M,PUMP MODEL No. ETN 80-250 GC, MAKE- KSB, APPLICATION: HOT WATER PUMP	NOS	4		
71	CASING WEARRING,PART NO.502.2,MOC- CF8M,PUMP MODEL No. ETN 80-250 GC, MAKE- KSB, APPLICATION: HOT WATER PUMP	NOS	4		
72	SHAFT SLEEVE-GLAND PACKING , PART NO.524, MOC-410 H , PUMP MODEL No. ETN 80-250 GC, MAKE- KSB, APPLICATION: HOT WATER PUMP	NOS	4		
73	IMPELLER , PART NO..230,MOC-CF 8M, PUMP MODEL No. ETN 80-250 GC, MAKE- KSB, APPLICATION: HOT WATER PUMP	NOS	4		
74	VOLUTE CASING, PART NO.102, MOC-CI, PUMP MODEL No. ETN 80-250 GC, MAKE- KSB, APPLICATION: HOT WATER PUMP	NOS	4		
75	IMPELLER FOR 1270 MM DIA SIPSC -05, FAN TIP SPPED 198.16MM/SEC ,FAN RPM 2890 MAKE : ANDREW & YULE OR EQUIVALENT CO , APPLICATION :ASH COOLER FAN	NOS	1		
<b>Total Amount Rs (Excluding GST)</b>					



**Please note the following details for Compulsory e-confirmation for Bank Guarantee through ICICI Bank through SFMS under our:**

**IFS Code: ICIC0000024 and UIC GMDC530265584 for Field 7037.**

**Bank Name: ICICI BANK LTD.**

**FORMAT OF BANK GUARANTEE FOR EARNEST MONEY DEPOSIT (EMD)**

(On Non-judicial Stamp paper to be submitted along with submission of bids)

..... (Name of the Bank)

Address.....

Guarantee No.....

A/C Messrs..... (Name of Bidder)

Date of Expiry.....

Limit to liability (currency & amount).....

Invitation For Tender No..... Dated.....( bidding document )

For..... (Name of Facilities)

**Subject:** Earnest Money Deposit Bank Guarantee.

Date.....20

To,

General Manger (\_\_\_\_),  
Gujarat Mineral Development Corporation Ltd.  
132 Ft Ring Road,  
Near University Ground  
Vastrapur,  
Ahmedabad.

Dear Sir,

In consideration of Gujarat Mineral Development Corporation (hereinafter called “GMDC”) which expression shall unless repugnant to the subject of context include his successors and assigns having agreed to exempt M/s..... (herein after called “Bidder”) from demand under the terms and conditions of “Technical Bid Document” ( hereinafter called the said “Bidding Document”) issued by the GMDC vide Tender No.\_\_\_\_\_for \_\_\_\_\_ the work\_\_\_\_\_



( Name of the facilities ) from Earnest Money Deposit (EMD) of Bid for the due fulfillment by the Bidder of the terms and conditions contained in the said Bidding Document on production of Bank Guarantee for INR \_\_\_\_\_ ( \_\_\_\_\_ only ) ( figure in words).

- 1.** We the \_\_\_\_\_ ( Name of Bank ) hereinafter referred to as “Bank” having our registered office at \_\_\_\_\_ ( address of Bank ) do hereby undertake and agree to indemnify and keep indemnified GMDC to extent of INR \_\_\_\_\_ ( \_\_\_\_\_ only ) ( figures in words ) against any losses, damage cost, charges and expenses caused to or suffered by or that may be caused or suffered by GMDC by reason of any breach or breaches by the Bidder of any of the terms and conditions contained in the said Bidding Document and unconditionally pay the amount claimed by GMDC on demand and without demur to the extent aforesaid.
- 2.** We \_\_\_\_\_ (Name of Bank) do hereby undertake to pay the amounts due and payable under the guarantee without any demur merely on a demand by you stating that the amount claimed is due by way of loss or damage caused to or would be caused or suffered by you by reason of any breach by the said Bidder of any of the terms or conditions contained in the said Bidding Document by reason of the Bidder’s failure to fulfill the conditions of said Bidding Document. Any such demand on the Bank shall be conclusive as regards the amount due and payable by the Bank under this guarantee. However, our liability under this guarantee shall be restricted to an amount not exceeding INR \_\_\_\_\_.
- 3.** We \_\_\_\_\_ ( Name of Bank ) further agree that GMDC shall be the sole judge of and as to whether the Bidder has committed any breach or breaches of terms and conditions of the said Bidding Document and the extent of loss, damages, costs, charges and expenses caused to or suffered by or that may caused to or suffered by GMDC on account hereof to the extent of the Bid Security required to be deposited by the Bidder in respect of the said document and the decision of GMDC that the Bidder has committed such breach or breaches and as to the amount or amounts of loss, damages, costs, charges, and expenses caused to or suffered by or that may be caused to or suffered by GMDC shall be final and binding on us.
- 4.** We \_\_\_\_\_ (Name of Bank) further agree that guarantee herein contained shall remain in full force and effect during the period that would be taken for the performance on the said Bidding Document and that it shall continue to be enforceable till you certify that terms and conditions of the said Bidding Document have been fully and properly carried out by the said Bidder and accordingly discharge the guarantee. Unless a demand or claim under this guaranteed is made on us in writing on or before the (date) \_\_\_\_\_ we shall be discharged from all liability under this guarantee.
- 5.** We \_\_\_\_\_ ( Name of Bank ) further agree with you that you have the fullest liberty without our consent and without affecting in any manner our obligations hereunder to vary any of the terms and conditions of the said Bidding Document or to extend time of performance by the said Bidder from time to time or to postpone for any time or from time to time any of the powers exercisable by you against the said Bidder and to forbear or enforce any of the terms and conditions relating to the said Bidding Document and we shall not be relieved from our liability by reason of any such variation or extension being granted to the said Bidder or for any forbearance act or omission on your part or any indulgence by you to the said Bidder or any such matter or thing whatsoever under the law relating to sureties would but for this provision have effect of so relieving us.



- 6.** It shall not be necessary for GMDC to proceed against the Bidder before proceeding against the Bank and the Guarantee herein contained shall be enforceable against the Bank, notwithstanding any security which GMDC may have obtained from the Bidder at this time when proceeding are taken against Bank hereunder be outstanding or unrealized.
- 7.** We \_\_\_\_\_ (Name of Bank) further undertake to unconditionally pay the amount claimed by GMDC merely on demand and without demur to the extent aforesaid.
- 8.** We, the said Bank lastly undertake not to revoke this guarantee during its currency except with the previous consent of GMDC in writing.
- 9.** This Guarantee will not be discharged due to the change in the constitution of the Bank or the said bidder.
- 10.** The Bank has under its constitution power to give this guarantee and Mr. \_\_\_\_\_ who has signed it on behalf of the Bank have authority to do so.

Yours faithfully  
For.....

(Name of the Bank)

Notwithstanding anything contained hereinabove

- (I) Our liability under this Bank Guarantee shall not exceed **Rs** \_\_\_\_\_/- (**Rupees** \_\_\_\_\_ **only**)
- (II) This Bank Guarantee is valid up to \_\_\_\_\_ (Date).
- (III) We are liable to pay the guarantee amount or any part thereof under this bank Guarantee only and only if you serve upon us a written claim or a demand on or before \_\_\_\_\_ (date).
- (IV) This bank guarantee is operative only when accompanied with SFMS advice from us.

Yours faithfully  
For \_\_\_\_\_ (Name of the Bank)

**Yours faithfully**  
**For.....**  
**(Name of the Bank)**

Annexure-D DRW

**SR NO.07 HELICAL GEAR PINION SHAFT PART NO.41**

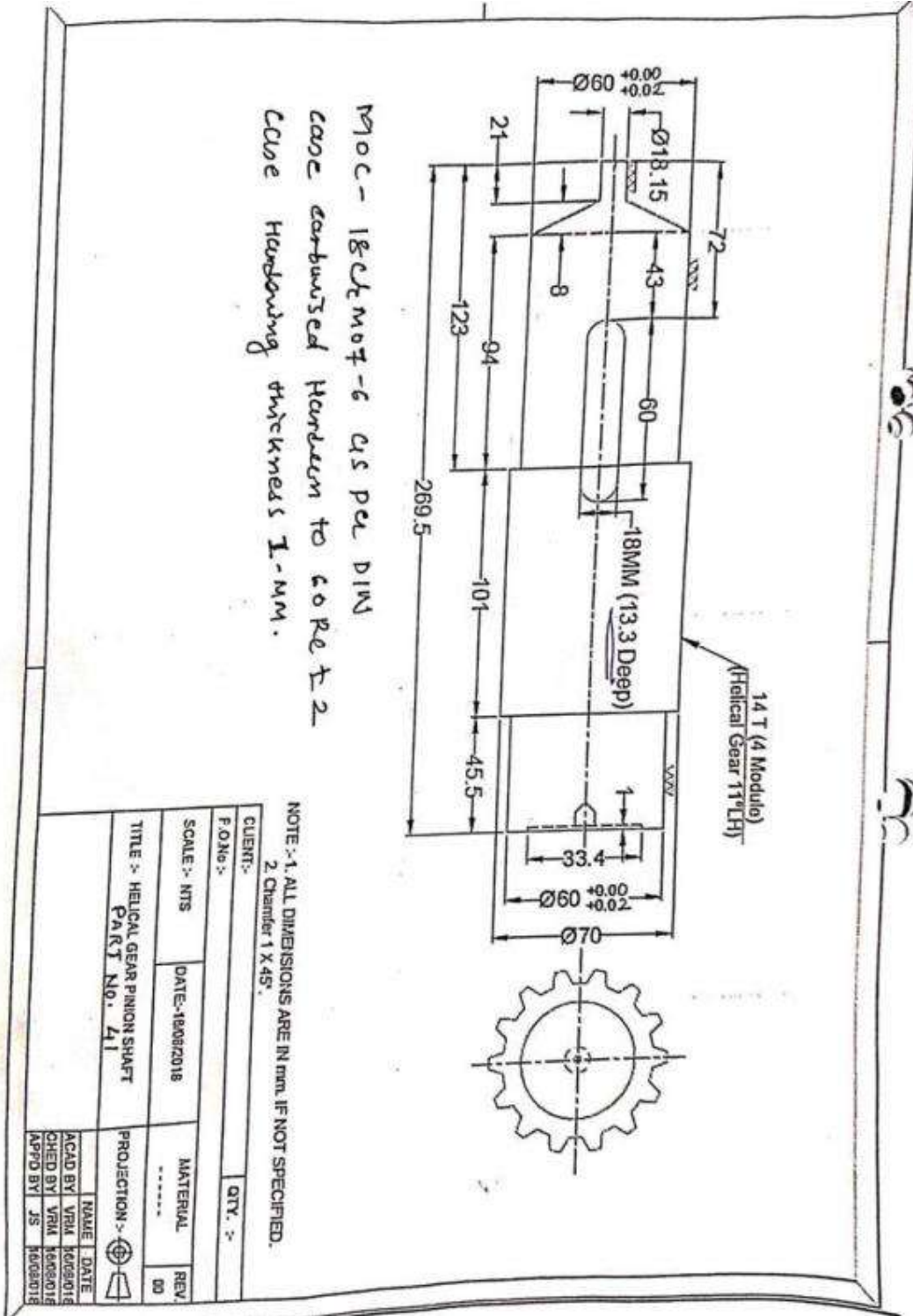

NOTE :- 1. ALL DIMENSIONS ARE IN mm. IF NOT SPECIFIED.  
2. Chapter 1 X 45°

CLIENT:-		QTY. :-	
F. ONe :-			
SCALE :- MTS	DATE:-18/08/2018	MATERIAL	REV
TITLE :- HELICAL GEAR PINION SHAFT		*****	00
PART No. 41		PROJECTION :-	
ACAD BY	NAME	DATE	
VRM	VRM	18/08/2018	
CHEK BY	VRM	18/08/2018	
APPD BY	JS	18/08/2018	

SR. NO.07 HELICAL GEAR WHEEL PART NO. 51

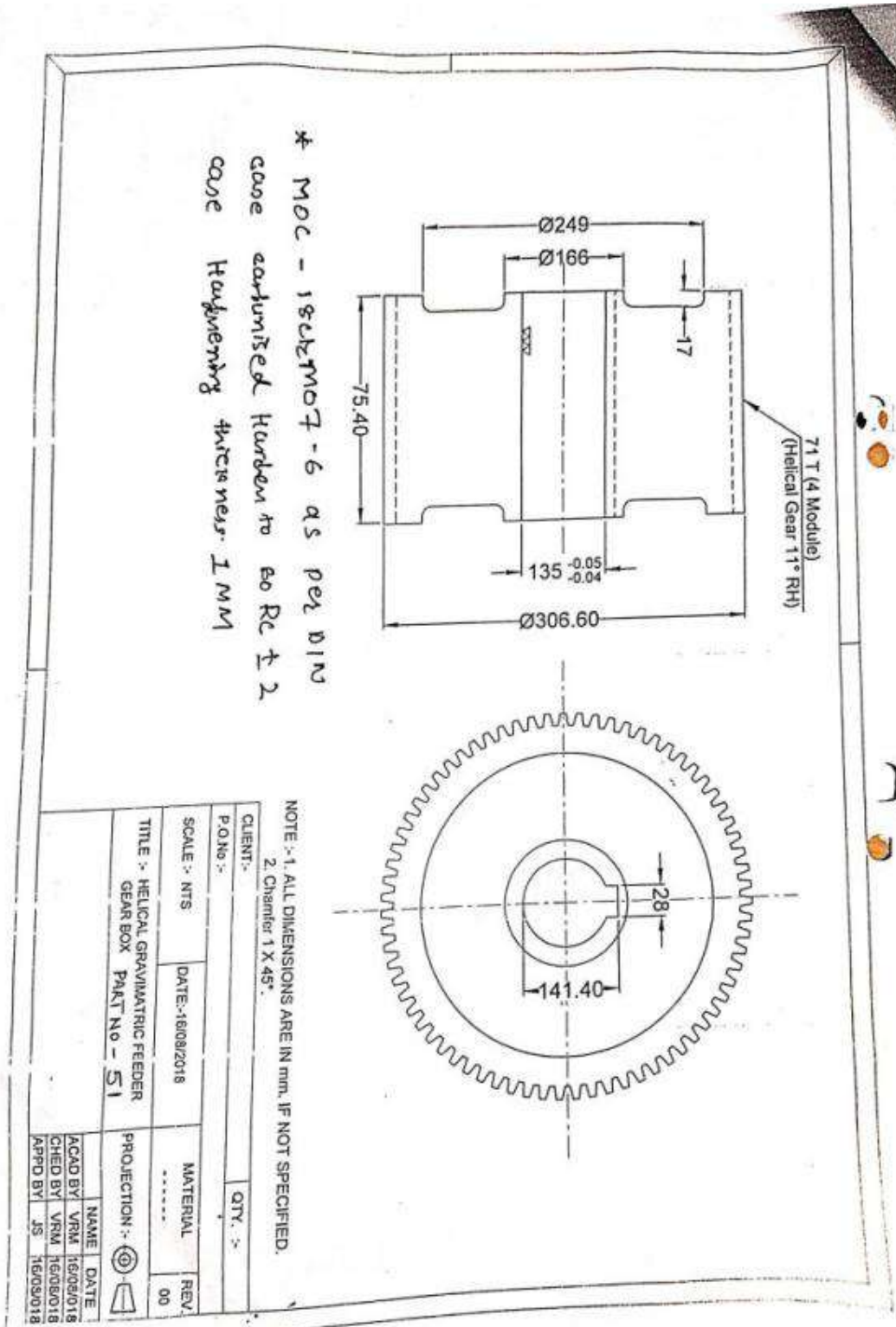

SR NO.08 HELICAL PINION SHAFT PART NO.42 GRAVIMETRIC FEEDER

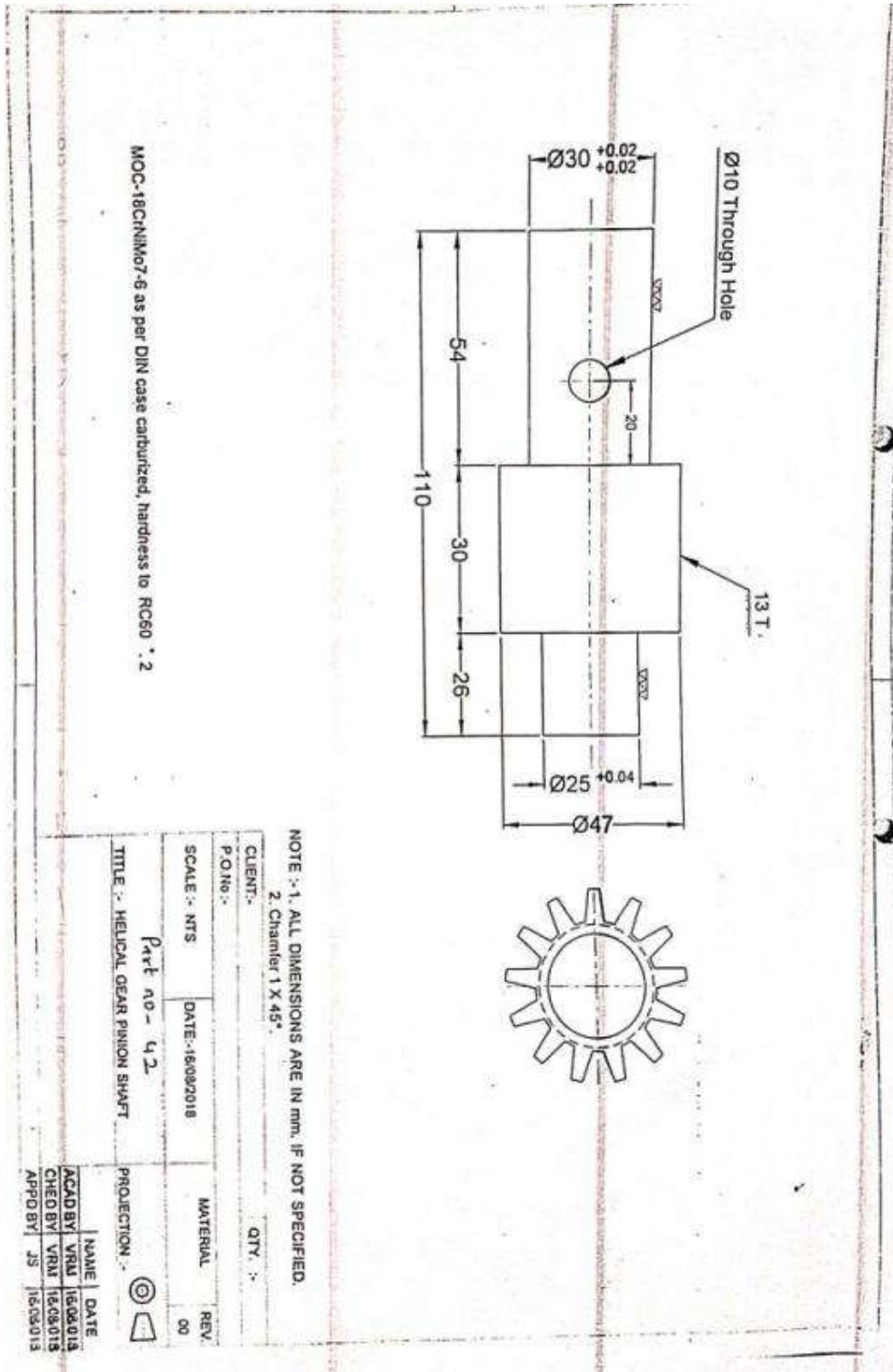

SR NO.08 HELICAL GEAR PART NO.52

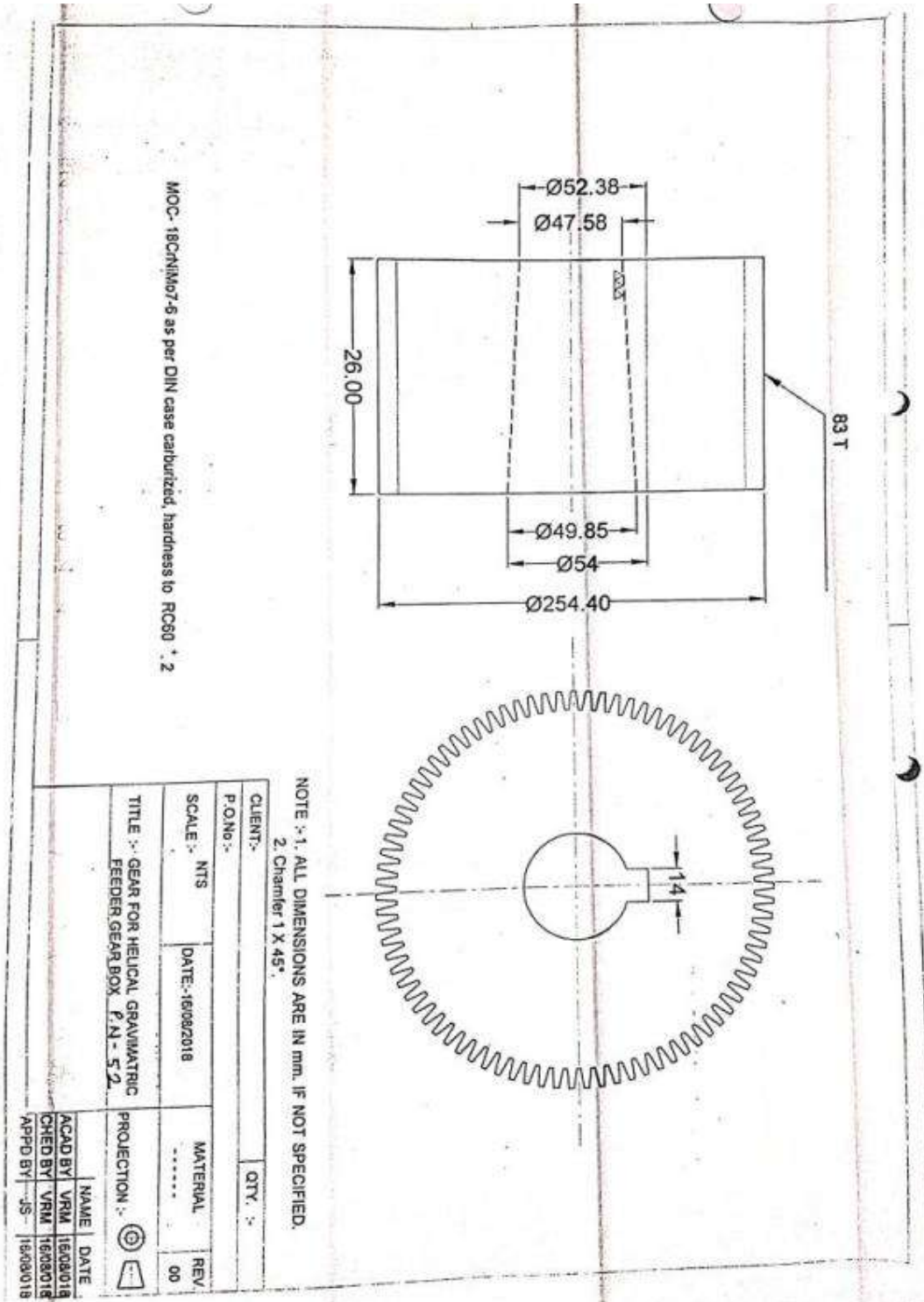

SR NO.10 BEVEL PINION SHAFT PART NO. 43

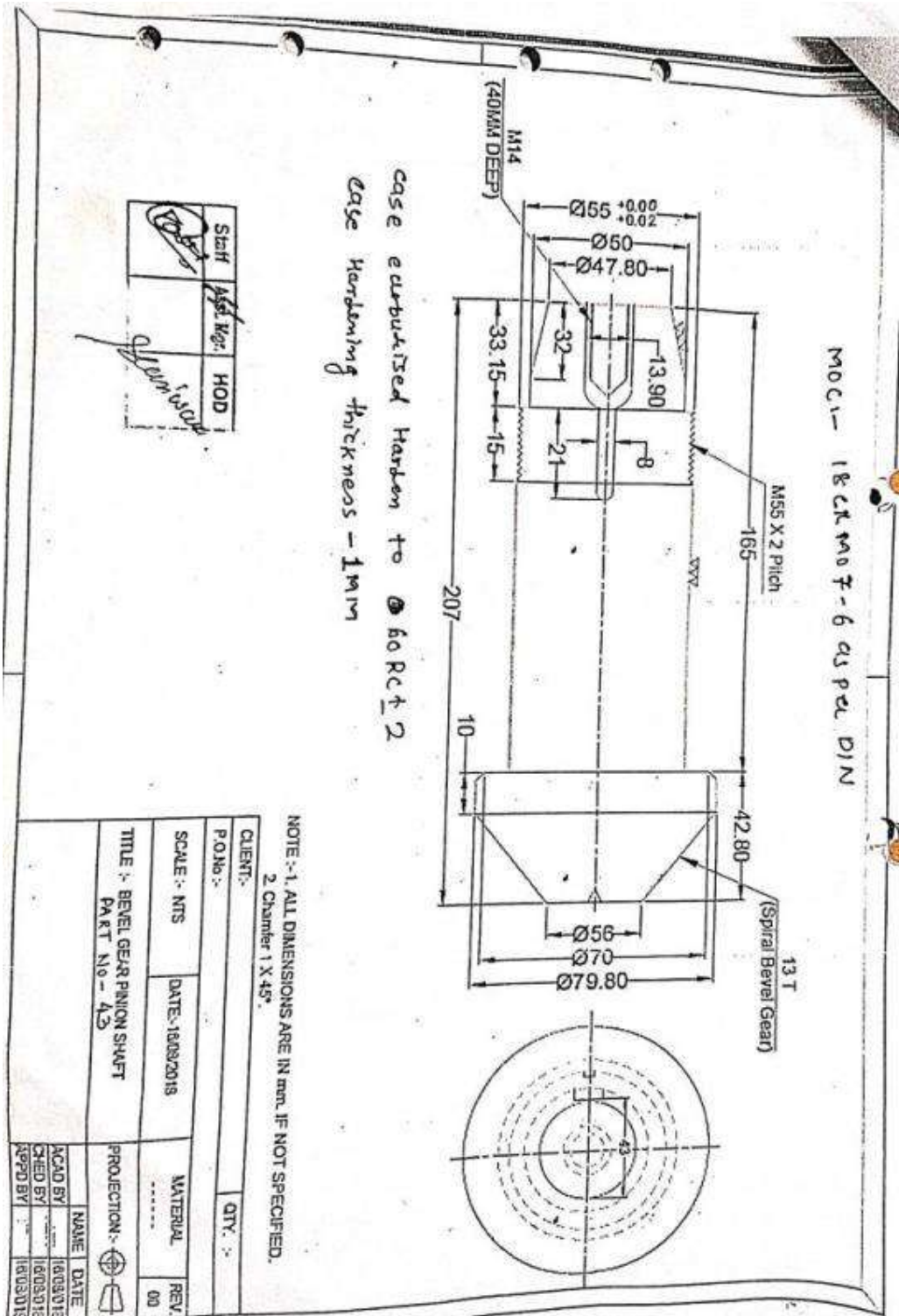

SR NO.10 BEVEL WHEEL PART NO. 53

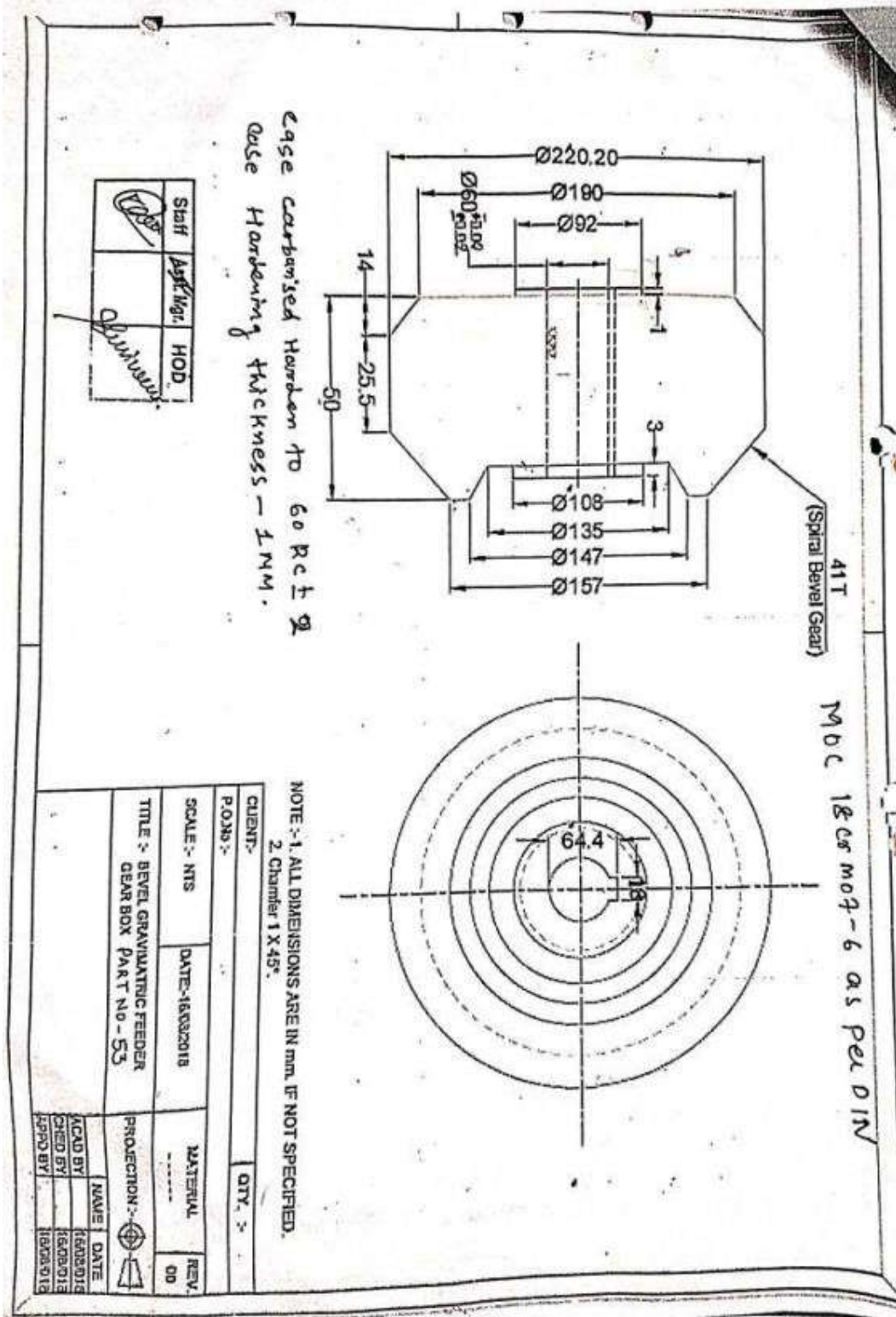



SR NO.09 INPUT PINION SHAFT WITH DISTANCE PIECE

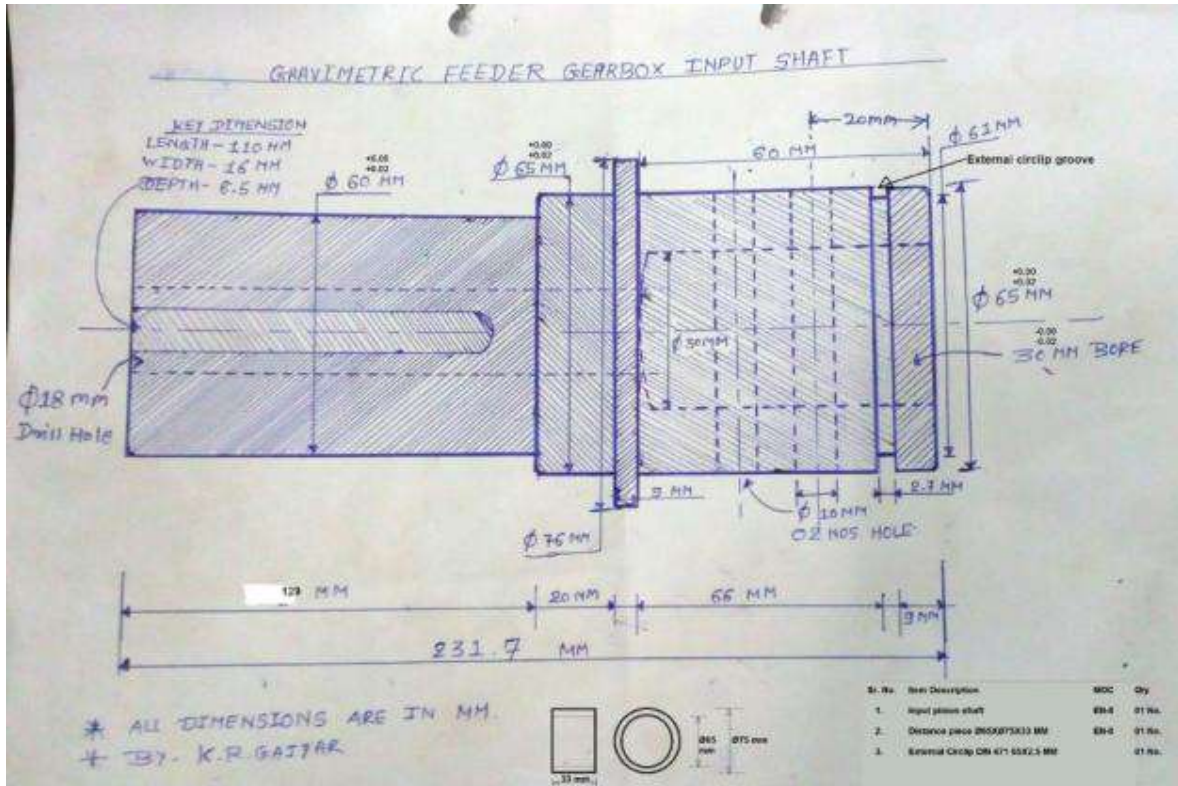

SR. NO. 21& 22 COC LINK WITHOUT FLIGHT

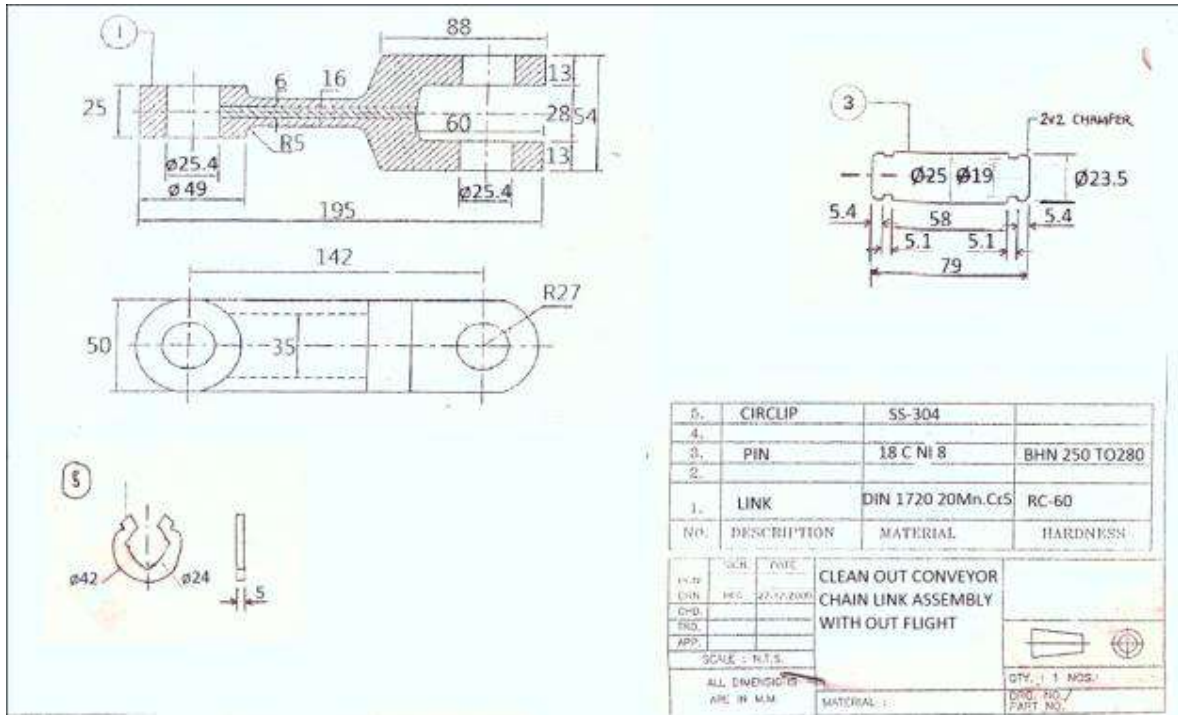

COC LINK WITH FLIGHT

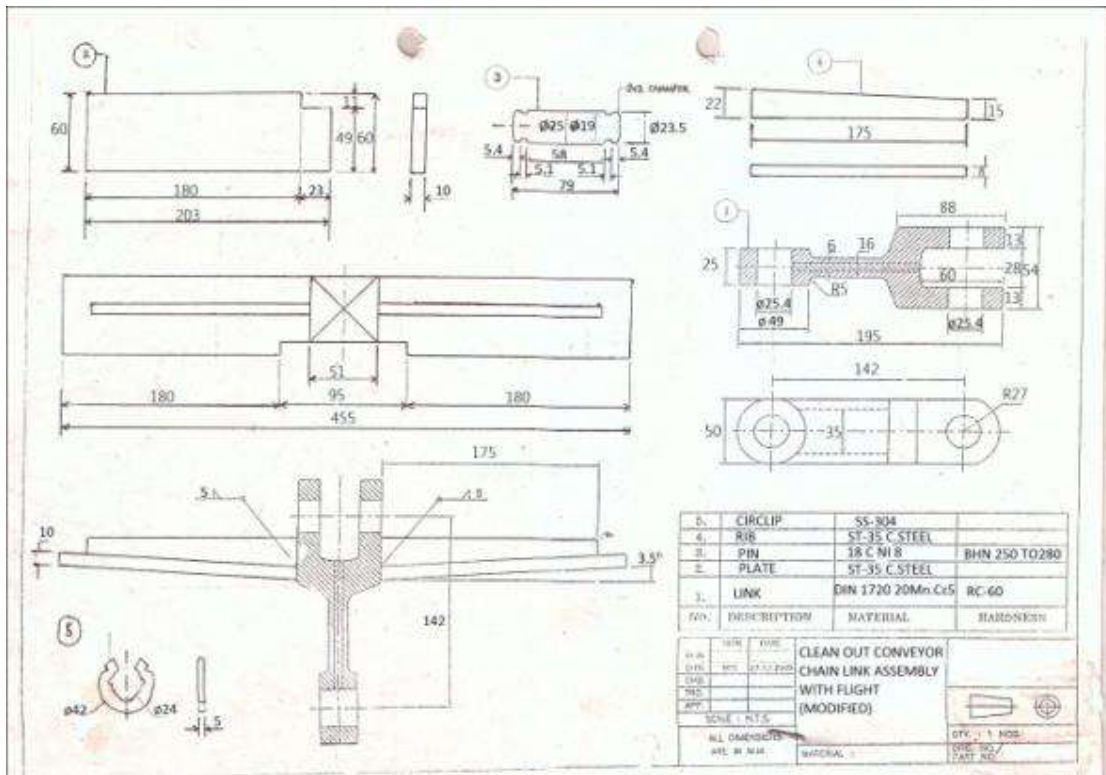

SR. NO.29 RALF GATE SPECIAL BOLT

RALF GATE TRAVELLING ROLLER AND BOLT

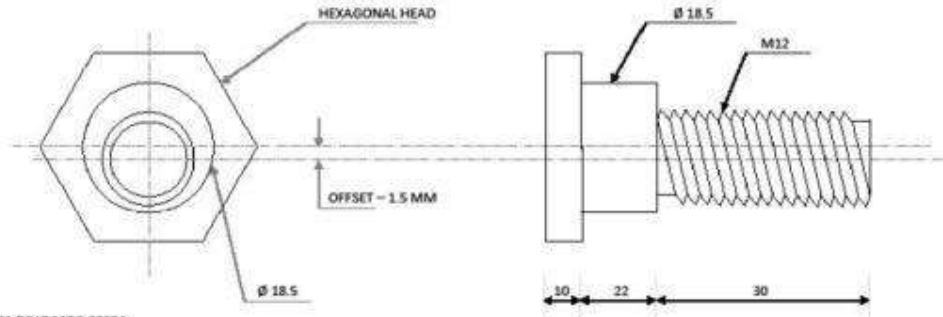

SPECIAL BOLT MOC-SS304

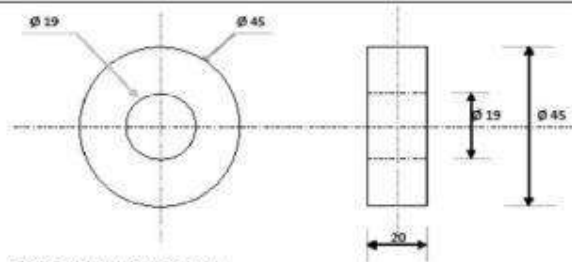

TRAVELLING ROLLER MOC-SS304

ALL DIMENSION ARE IN MM

NTS



SR .NO.20 GRAVIMETRIC FEEDER TAIL END PULLEY 01 OF 06

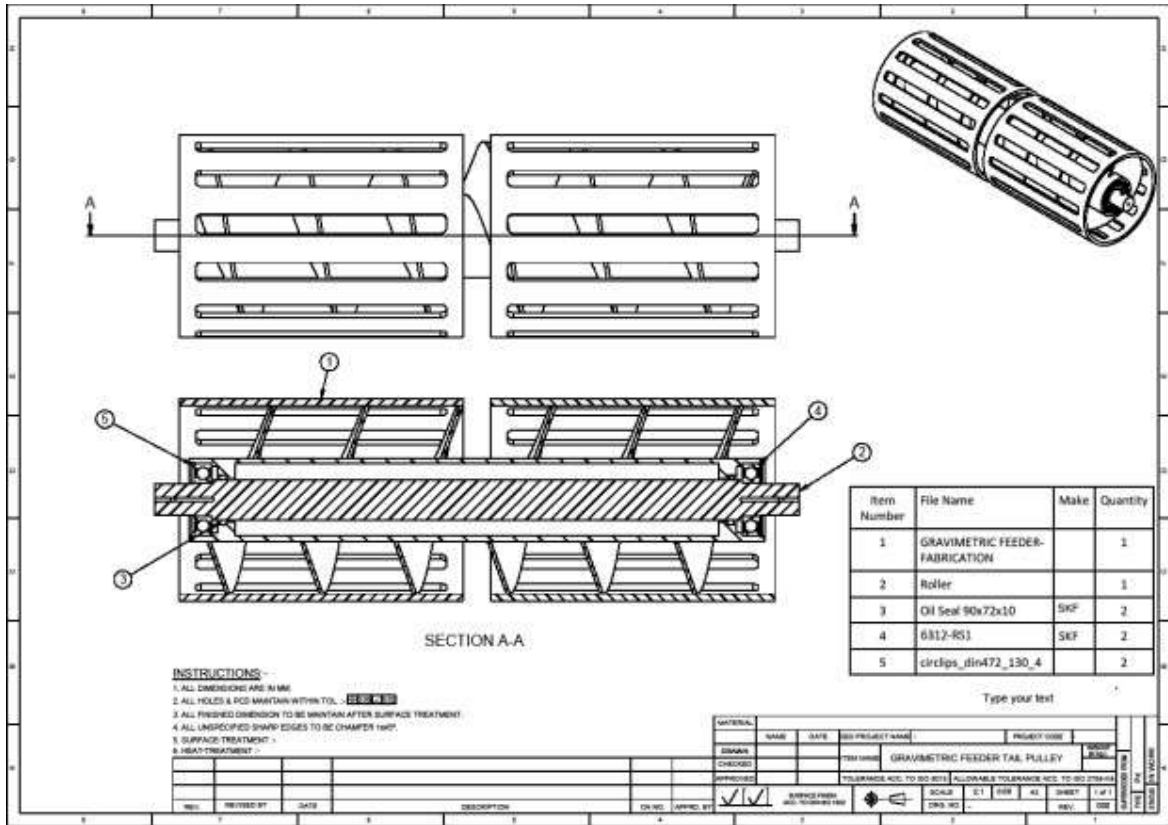

**SECTION A-A**

Item Number	File Name	Make	Quantity
1	GRAVIMETRIC FEEDER-FABRICATION		1
2	Roller		1
3	Oil Seal 90x72x10	SKF	2
4	6312-RS1	SKF	2
5	circlips_din472_130_4		2

Type your text

MATERIAL	NAME	DATE	DESIGN PROJECT NAME	PROJECT CODE	SCALE	DATE	REV	BY	CHKD	APPD	DRG NO.	REV	DATE
			GRAVIMETRIC FEEDER TAIL PULLEY										

**INSTRUCTIONS:-**  
 1. ALL DIMENSIONS ARE IN MM  
 2. ALL HOLES & RCD MOUNTAIN WITHIN TOL. **±0.05**  
 3. ALL FINISHED DIMENSION TO BE SHOWN AFTER SURFACE TREATMENT  
 4. ALL UNSPECIFIED SHARP EDGES TO BE CHAMFER 1MM.  
 5. SURFACE TREATMENT :-  
 6. HEAT TREATMENT :-

NO.	REVISED BY	DATE	DESCRIPTION	DR. NO.	APPROVED BY	DATE

GRAVIMETRIC FEEDER TAIL END PULLEY 02 OF 06

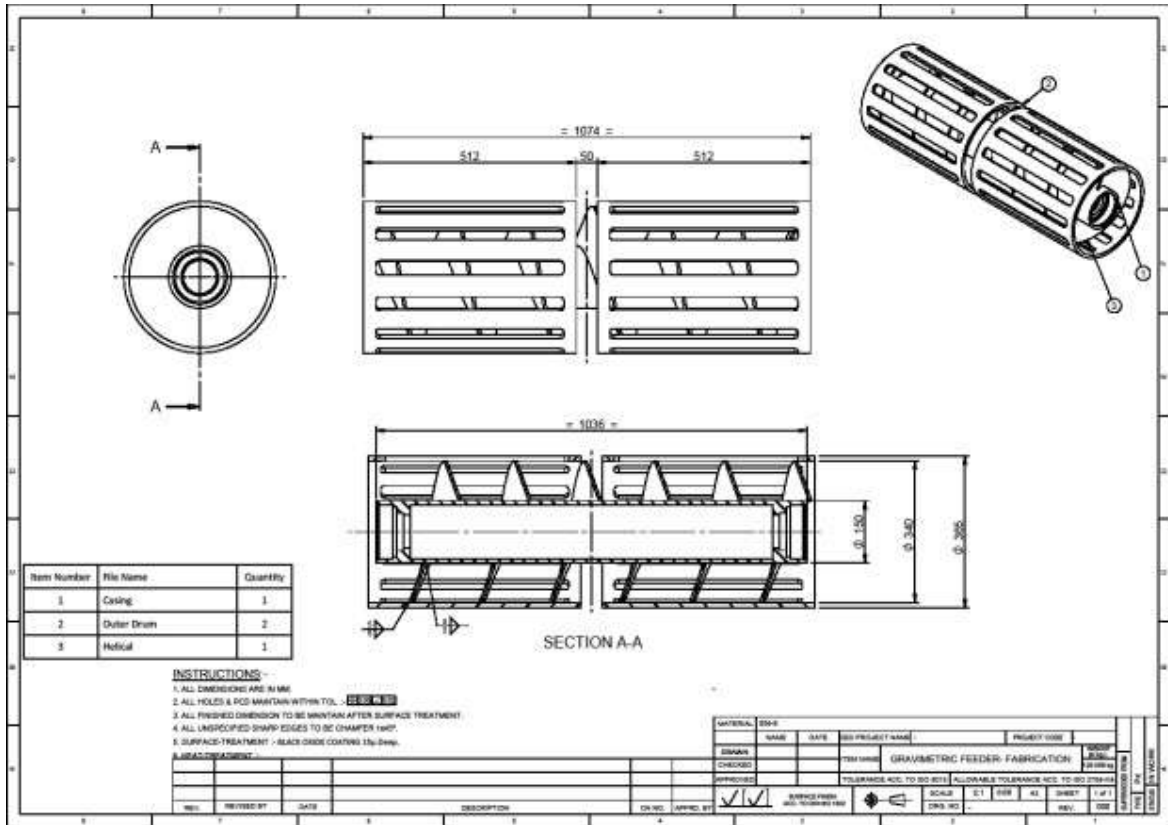





GRAVIMETRIC FEEDER TAIL END PULLEY 04 OF 06

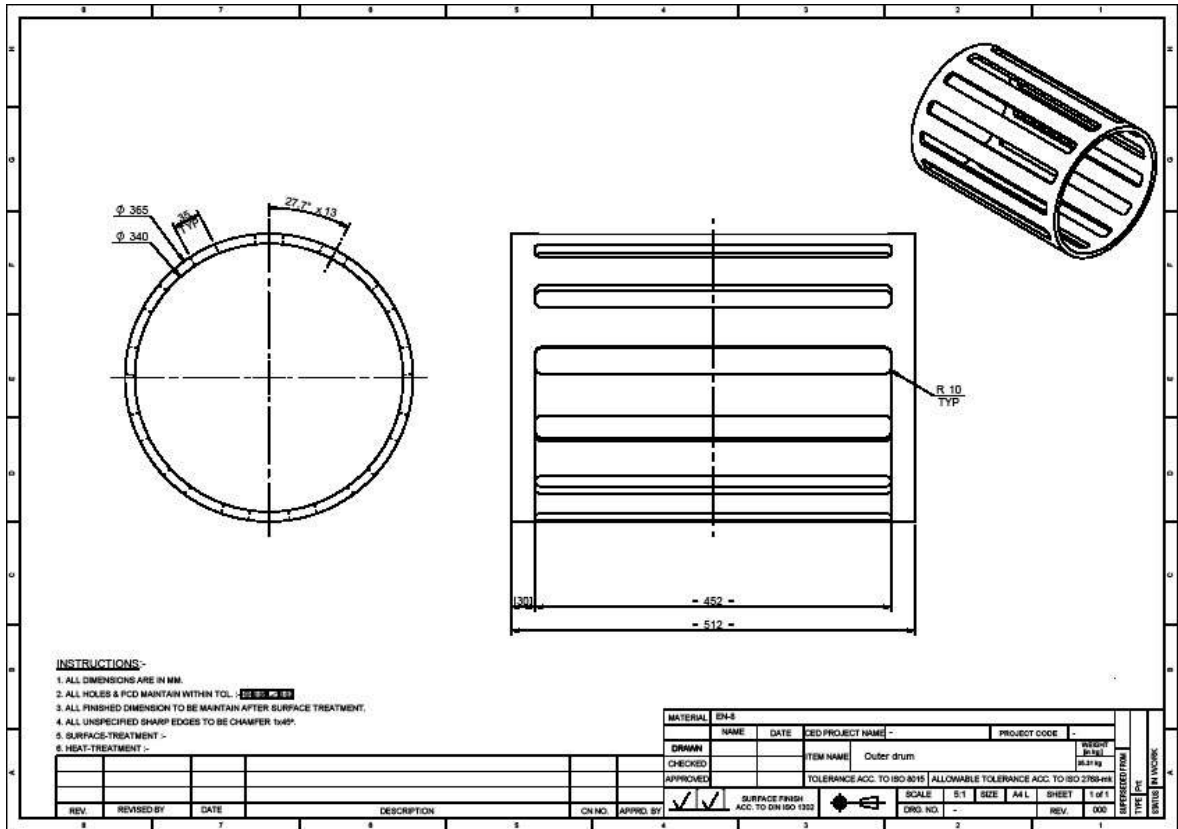





GRAVIMETRIC FEEDER TAIL END PULLEY 06 OF 06

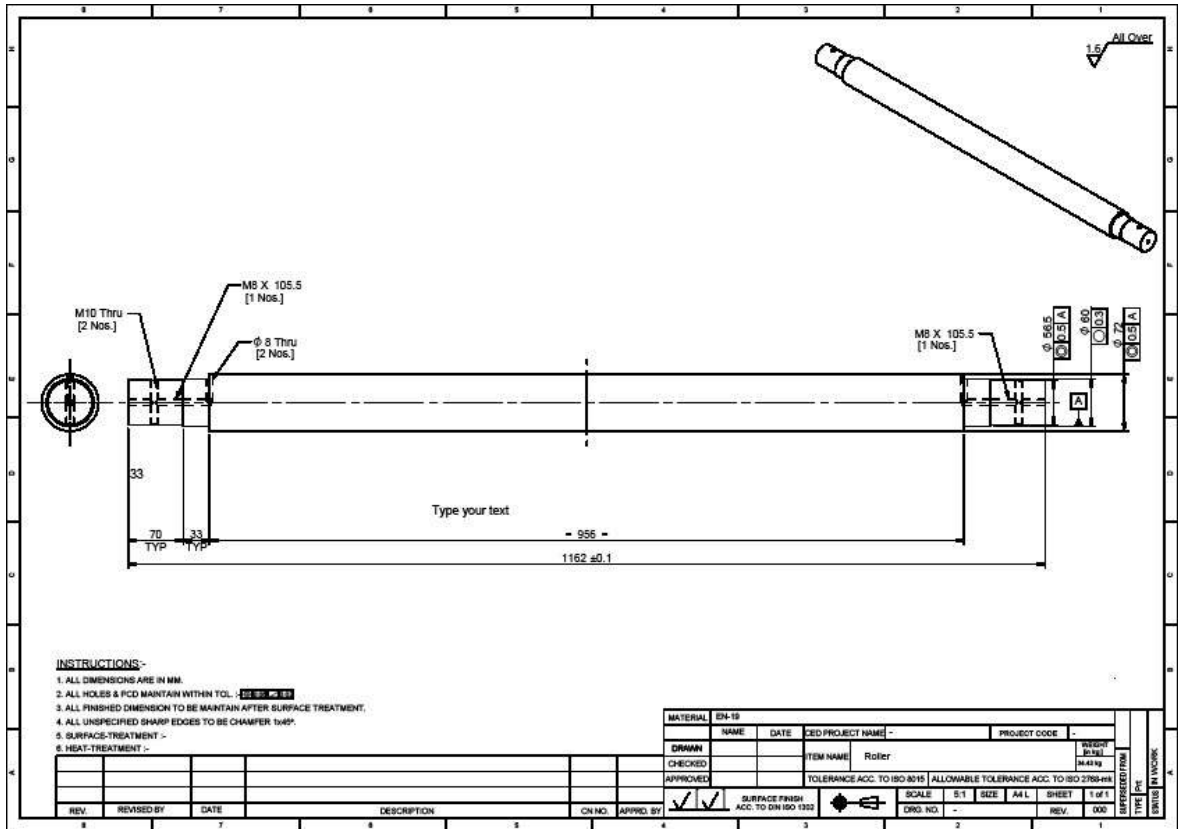

SR.NO.41 ASH DRAG LINK CONVEYOR

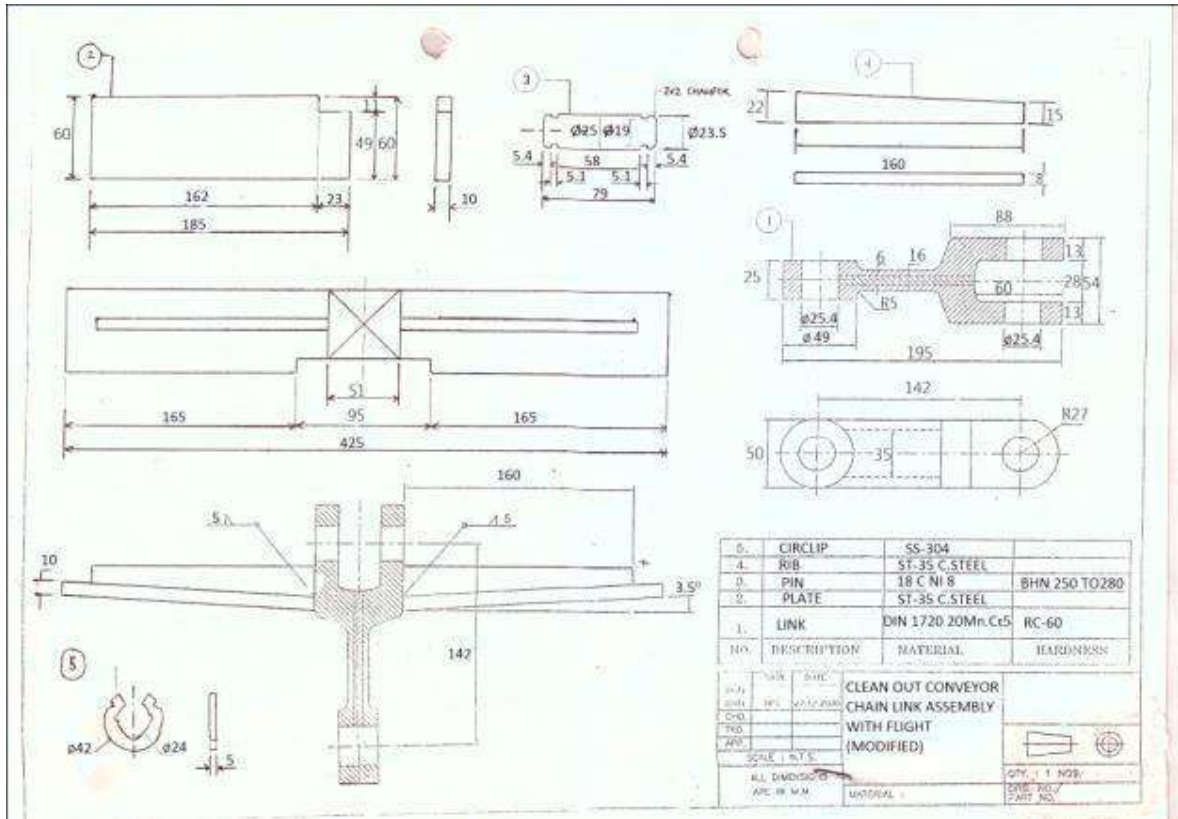

**SR NO.02 TO 04 ANCHOR**

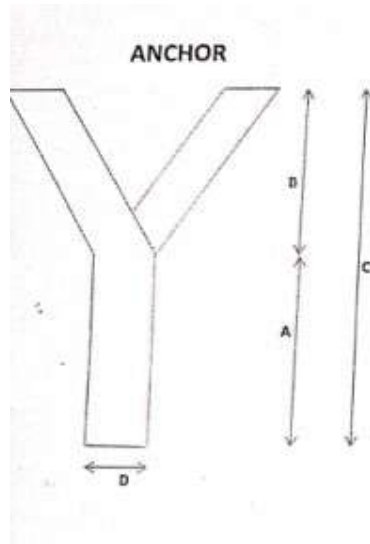

Type	A	B	C	D	THICKNESS	APPLICATION
AN-1	130	100	230	25	5	ASH COOLER AND L-VALVE
AN-2	120	100	220	25	5	RC LINE ASH COOLER
AN-3	60	40	100	20	5	RTZ AREA
AN-4	200	130	330	30	6	SYPHONE SEAL AND DOWN CORNER
AN-5	270	150	420	30	6	CYCLONE I/L O/L, ROOF, WALL
CORRUGATED	10X55MM					FURNACE

ALL DIMENSION IN MM AND NTS  
THICKNESS



SR. NO.51 Cyclone Inlet Bellow

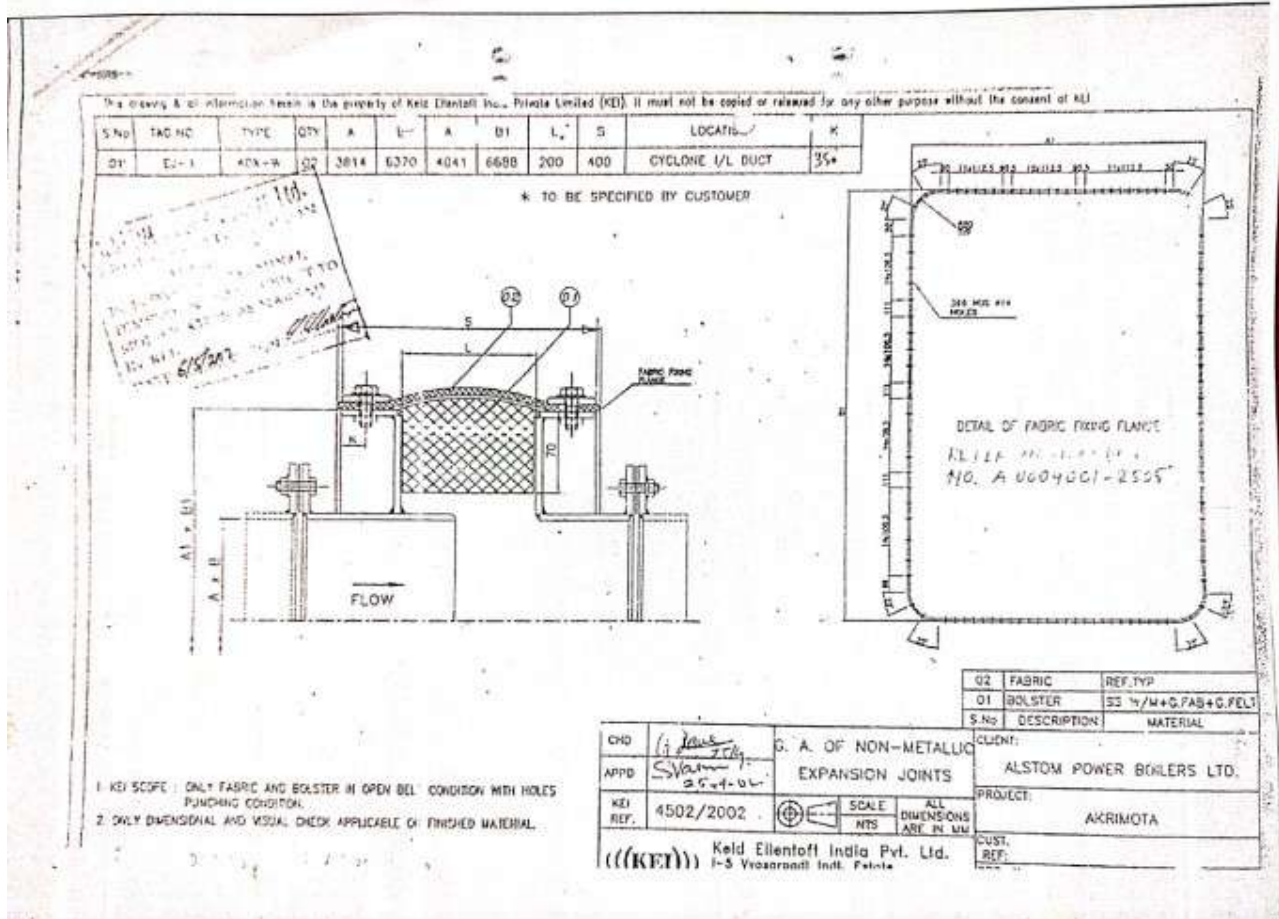

SR. NO.36 HRSB Lance of Soot blower

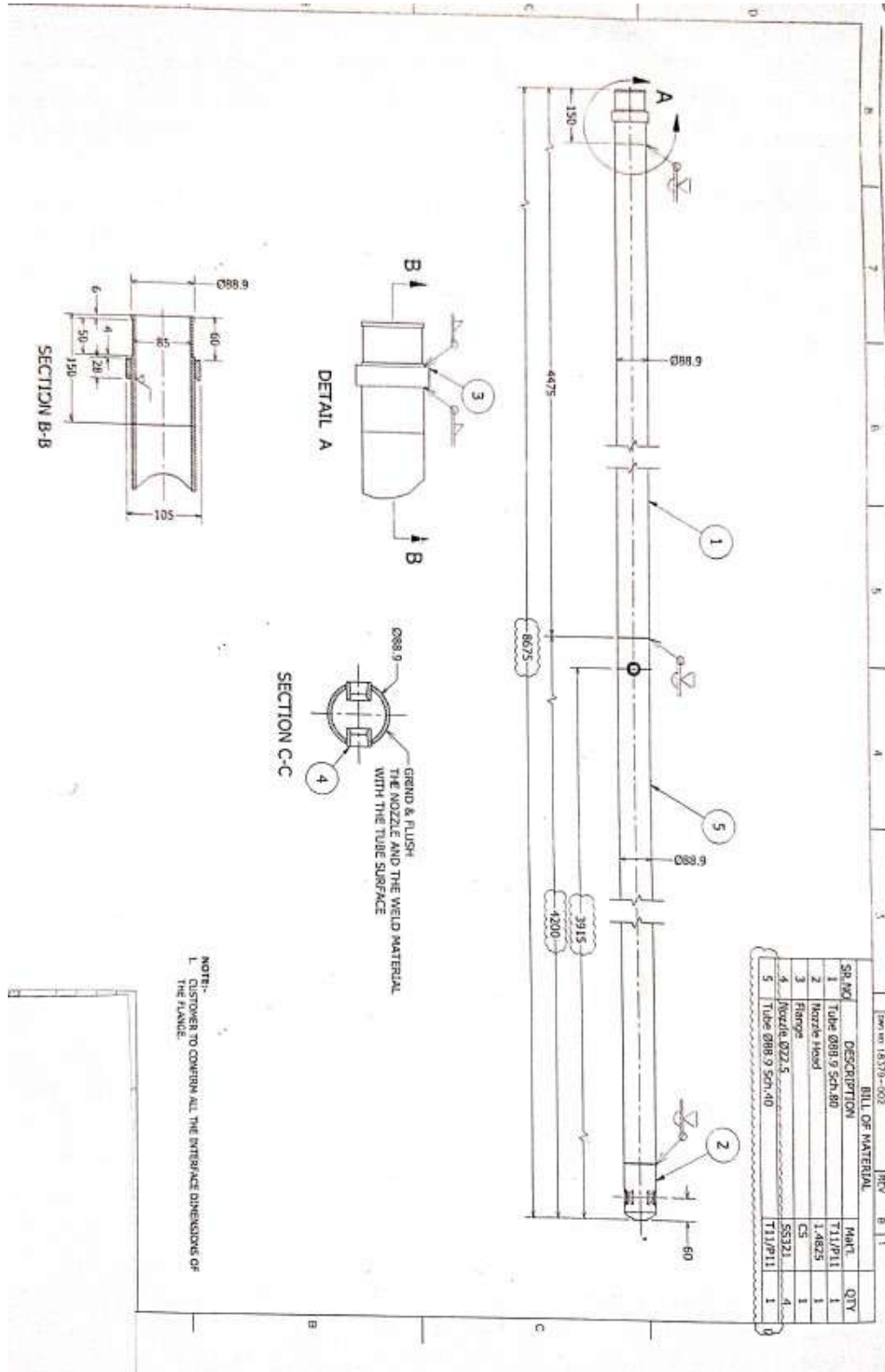

SR. NO.35 LRSB Soot blower Lance

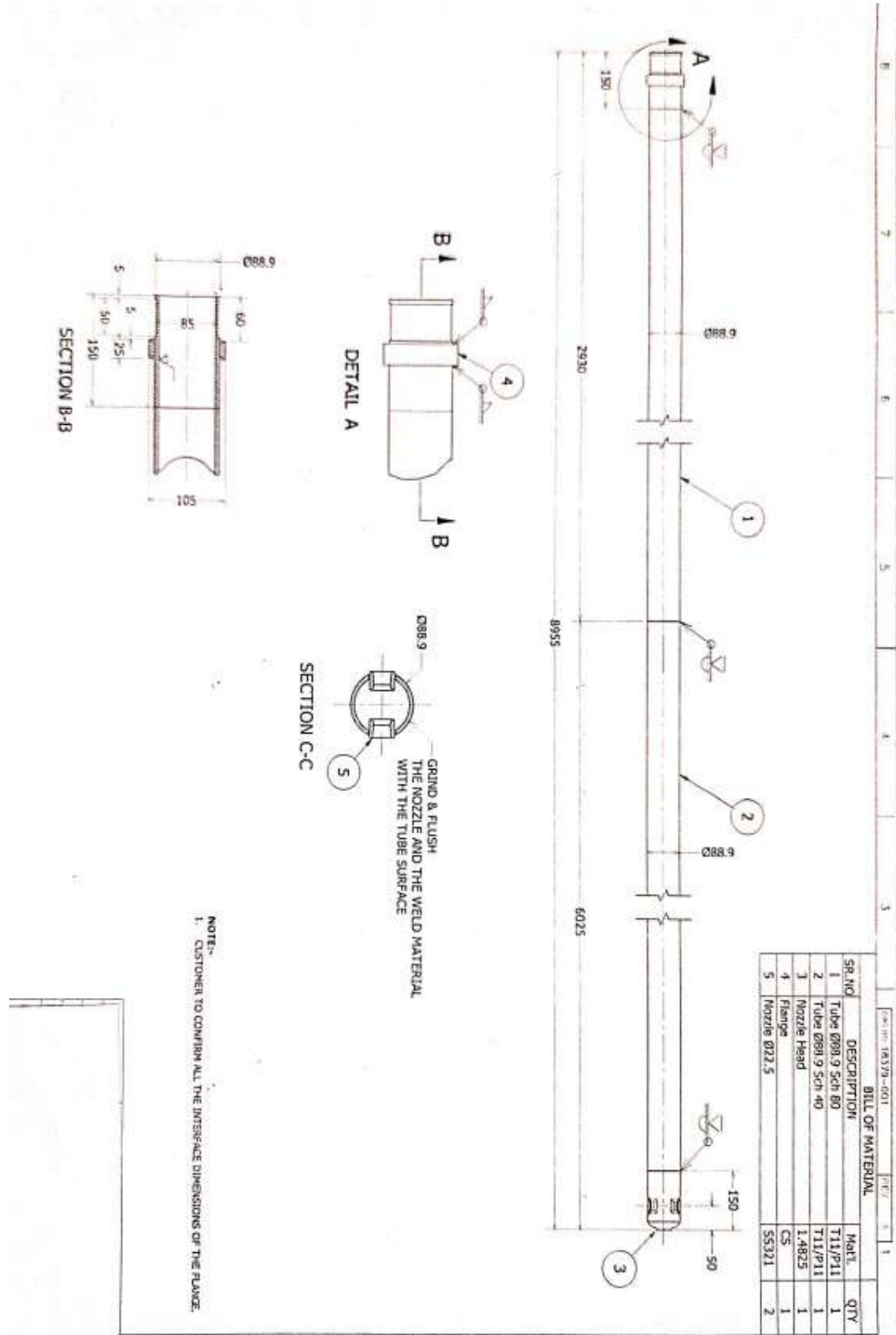

NOTE:-  
1. CUSTOMER TO CONFIRM ALL THE INTERSPACE DIMENSIONS OF THE FLANGE.



SR NO.39,40 Shield

